

# JUNG PUMPEN MULTISTREAM

## SEWAGE PUMPS

### APPLICATION

The centrifugal submersible sewage pumps MultiStream are suitable for handling effluent or sewage in municipal and industrial pumping stations as well as in surface water drainage applications. The smaller types are also used very successfully as portable units to deal with emergency situations.

- The sewage pumps are suitable für handling sewage water.
- In hazardous locations explosion-proof sewage pumps Ex have to be used.

The adjustable axial gap of the MultiStream-pump makes it possible to re-optimize the efficiency in case of abrasion by adjusting only one single screw. This can be done very cost-effective when the maintenance is carried out and the pump keeps its optimum performance on a long-term basis.

MultiStream-pumps are recommended for:

- effluent which contains fibrous matter
- effluent which contains solids
- mixed water
- raw effluent
- raw sludge
- rainwater

### TECHNICAL DATA

#### Pump

Vertical, single-stage, submersible, pump case with horizontal discharge, single channel impeller and short shaft extension. This provides a longer service life for the ball bearings and the mechanical seal.

#### Bearings

Common shaft for pump and motor, deep groove and inclined ball bearings, grease-packed.

#### Seal

Silicon carbide mechanical seal independent of sense of rotation, oil chamber and artificial carbon mechanical seal or rather SiC mechanical seal (or duplex rotary shaft seal up to size 35) as secondary seal, safe to run dry.

#### Motor

Submersible, enclosure IP68, activation through special purpose plug or control unit, protected by winding thermostats, ex-proof types tested by PTB (German tech. inspection authority), type of protection  II 2 G Ex d IIB T4.

#### Materials

Pump, motor case and impeller in GG grey cast iron (single channel impeller with  $n = 2800 \text{ min}^{-1}$  from size 55/2 in spheroidal graphite iron GGG), corrosion protected shaft (no contact with pumped liquid), flexible rubber sheathed cable.

#### Installation

Install pump vertically with guide rail system or pump base. Flange coupling according to DIN, coupling size B or hose tail bend up to 3" possible.



Types of operation: Up to 40°C medium temperature  
 Motor submerged: continuous operation S1  
 Motor not submerged intermittent operation S3  
 (e.g. 15% = 1.5 min operation and 8.5 min pause)

- Adjustable single-channel impeller
- Connection alternatively PN 6 or PN 10
- Safe to run dry
- Controllable oil chamber
- Plug type cable connection (10...-100...)
- SiC mechanical seal independent of sense of rotation
- Moisture sealed cable inlet
- Built-in motor protection

#### Scope of supply

Pump acc. to EN 12050 with 10 m cable without plug, without pump base:

- a) as sewage pump
- b) as explosion-proof sewage pump Ex



# JUNG PUMPEN MULTISTREAM SEWAGE PUMPS

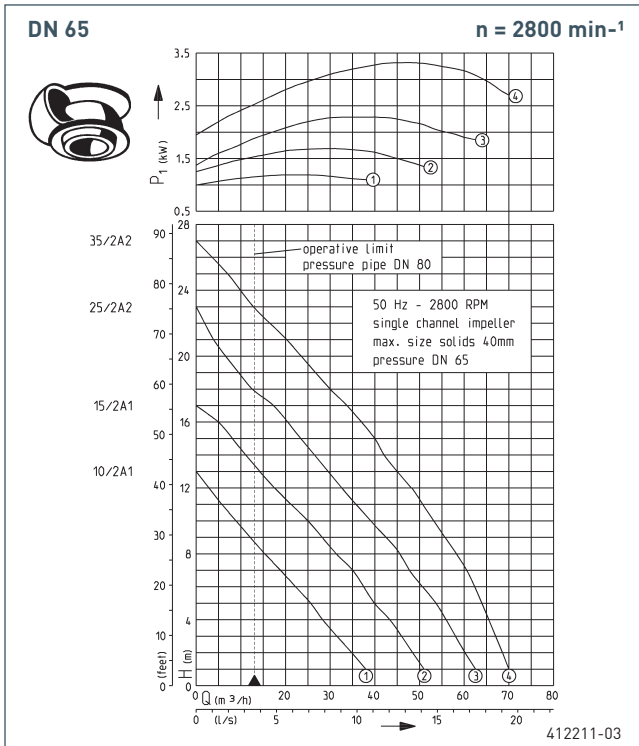

The minimum flow rate in the pressure pipe of  $v = 0,7 \text{ m/s}$  is marked in the Q-H diagram (operative limit).  
Pump performance is subject to ISO 9906 tolerances.

## PERFORMANCE

Type	1	2	3	4	5	6	7	8	9	10	12	14	16	18	20	22	24	H [m]	
10/2 A1	38	35	32	29	26	22	19	15	12	9									Flow rate Q [m <sup>3</sup> /h]
15/2 A1	50	48	46	43	40	37	35	32	28	25	18	11	5						
25/2 A2	62	60	58	56	54	51	48	46	42	39	33	27	20	13	7				
35/2 A2	70	69	67	66	64	63	61	58	56	53	48	43	37	30	24	16	10		

## TECHNICAL DATA

Type	Voltage (50 Hz) Volt	Max. Motor Rating (kW) P <sub>1</sub> P <sub>2</sub>	S3-% Operation Emerg Motor	Max. Current Ampere	RPM min <sup>-1</sup>	Cable (10 m) H07RN-F-	Fuse min.	Dis- charge branch PN 6/10	Max. Solid Size (mm)	Weight approx.
10/2 A1	3/PE~230/400	1.30 1.10	60	4.6/2.7	2943	° 6 G 1.5	10 A	DN 65	40	41 kg
15/2 A1	3/PE~230/400	1.80 1.50	50	5.7/3.3	2910	° 6 G 1.5	10 A	DN 65	40	42 kg
25/2 A2	3/PE~230/400	2.60 2.10	40	7.6/4.4	2860	° 6 G 1.5	10 A	DN 65	40	48 kg
35/2 A2	3/PE~230/400	3.70 3.04	40	11.5/6.6	2895	° 6 G 1.5	10 A	DN 65	40	52 kg

° plug-in

# JUNG PUMPEN MULTISTREAM SEWAGE PUMPS

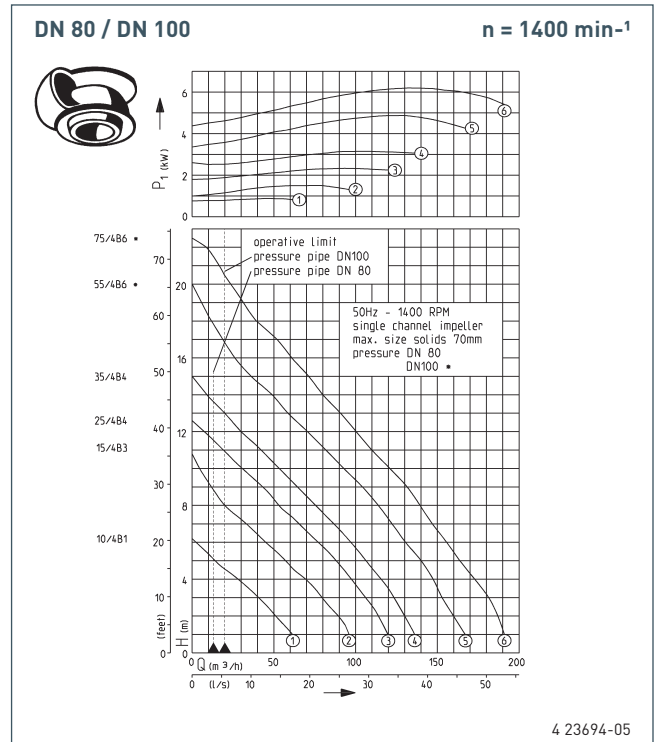
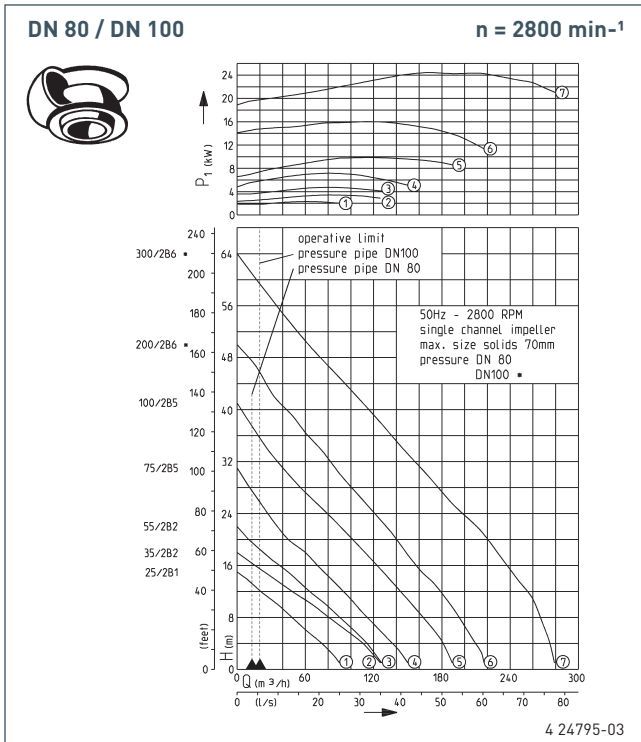

The minimum flow rate in the pressure pipe of  $v = 0,7$  m/s is marked in the Q-H-diagram (operative limit).

Pump performance is subject to ISO 9906 tolerances

## PERFORMANCE

Type	1	3	6	9	12	15	18	21	24	27	30	33	36	40	43	46	50	53	56	60	H [m]	
25/2 B1	91	80	62	43	21																	Flow rate Q [m³/h]
35/2 B2	126	117	97	73	49	23																
55/2 B2	127	118	103	85	65	44	24	6														
75/2 B5	150	142	126	110	93	77	59	42	27	15												
100/2 B5	190	184	173	159	144	129	113	97	78	63	46	32	18									
200/2 B6	217	215	204	191	177	162	149	136	120	104	91	77	62	43	28	19						
300/2 B6	280	277	270	263	254	242	229	216	199	183	167	152	136	113	100	84	63	49	34	17		
Type	1	2	3	4	5	6	7	8	9	10	11	12	14	15	16	17	18	20	H [m]			
10/4 B1	60	51	40	28	14	3															Flow rate Q [m³/h]	
15/4 B3	98	89	79	69	57	45	33	20	12	5												
25/4 B4	120	114	106	97	87	77	65	53	43	31	19											
35/4 B4	132	125	119	112	104	95	85	74	64	53	43	30	10									
55/4 B6	167	160	154	147	140	132	123	114	104	93	82	72	49	39	28	19	12					
75/4 B6	191	188	181	173	163	157	149	141	131	122	113	104	82	73	62	52	41	24				

## TECHNICAL DATA

Type	Voltage (50 Hz) Volt	Max. Motor Rating (kW) P <sub>1</sub> P <sub>2</sub>	S3-% Operation Emerg Motor	Max. Current Ampere	RPM min <sup>-1</sup>	Cable (10 m) H07RN-F-	Fuse min.	Discharge branch PN 6/10	Max. Solid Size (mm)	Weight approx.
25/2 B1	3/PE~230/400	2.60 2.10	40	7.6/ 4.4	2860	° 6 G 1.5	10 A	DN 80	70	45 kg
35/2 B2	3/PE~230/400	3.70 3.04	40	11.5/ 6.6	2895	° 6 G 1.5	10 A	DN 80	70	55 kg
55/2 B2	3/PE~400/690	5.20 4.45	40	8.7/ 5.0	2910	° 10 G 2.5	*16 A	DN 80	70	88 kg
75/2 B5	3/PE~400/690	7.70 6.60	30	13.2/ 7.7	2925	° 10 G 2.5	*20 A	DN 80	70	98 kg
100/2 B5	3/PE~400/690	10.50 9.20	30	17.6/10.2	2920	° 10 G 2.5	*25 A	DN 80	70	121 kg
200/2 B6	3/PE~400/690	17.30 15.40	45	28.8/16.7	2940	° 10 G 2.5	*35 A	DN 100	70	212 kg
300/2 B6	3/PE~400/690	27.00 24.45	35	43.0/24.7	2950	7G6+3x1	*50 A	DN 100	70	257 kg
10/4 B1	3/PE~230/400	0.95 0.73	50	4.2/ 2.4	1466	° 6 G 1.5	10 A	DN 80	70	45 kg
15/4 B3	3/PE~230/400	1.80 1.40	40	5.9/ 3.4	1426	° 6 G 1.5	10 A	DN 80	70	50 kg
25/4 B4	3/PE~230/400	2.70 2.04	25	7.9/ 4.6	1376	° 6 G 1.5	10 A	DN 80	70	59 kg
35/4 B4	3/PE~230/400	3.50 2.65	25	12.0/ 6.9	1424	° 6 G 1.5	10 A	DN 80	70	62 kg
55/4 B6	3/PE~400/690	5.80 4.65	20	10.2/ 5.9	1430	° 10 G 2.5	*16 A	DN 100	70	111 kg
75/4 B6	3/PE~400/690	7.20 5.90	25	12.8/ 7.4	1432	° 10 G 2.5	*20 A	DN 100	70	116 kg

° plug-in \*Value for Y/Δ-starting

# JUNG PUMPEN MULTISTREAM

## SEWAGE PUMPS

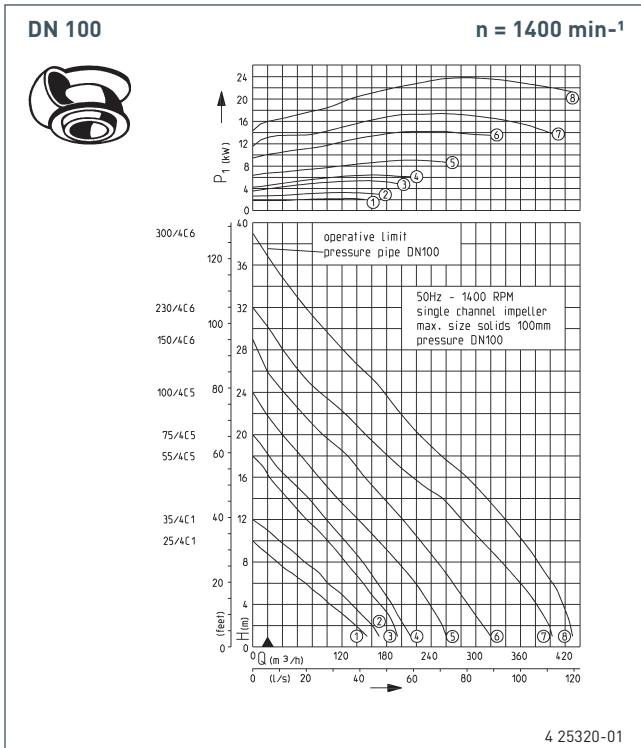

The minimum flow rate in the pressure pipe of  $v = 0,7$  m/s is marked in the Q-H-diagram

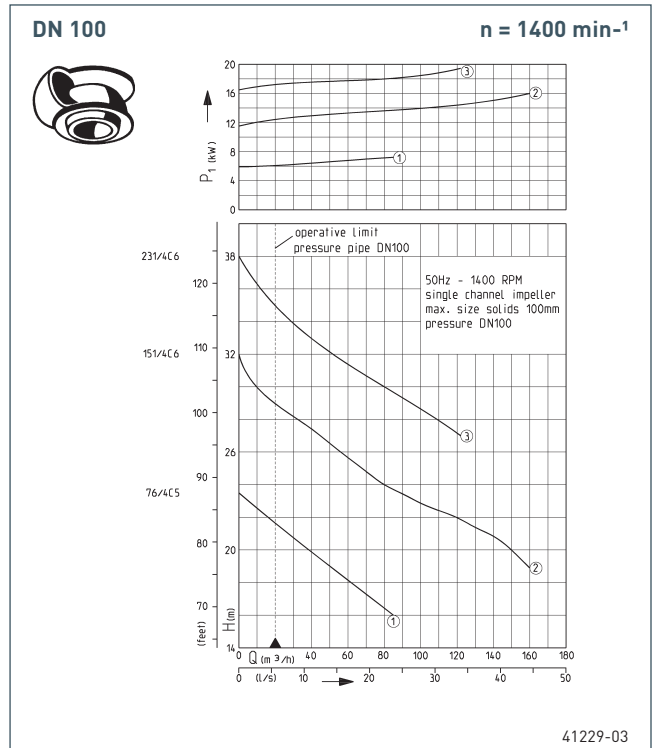

Pump performance is subject to ISO 9906 tolerances

### PERFORMANCE

Type	1	3	5	7	9	12	14	16	18	20	23	24	26	27	28	29	30	31	34	37	38	H [m]	
25/4 C1	154	122	87	51	16																		Flow rate Q [m³/h]
35/4 C1	170	146	119	89	54																		
55/4 C5	198	181	160	136	112	74	45	22															
75/4 C5	212	195	179	160	138	99	74	46	22														
100/4 C5	260	247	228	207	182	142	114	89	65	40	9												
150/4 C6	320	302	280	260	236	202	177	152	126	96	54	43	20	14	8								
230/4 C6	405	390	372	344	320	283	255	218	182	155	110	91	62	51	40	32	22	8					
300/4 C6	430	421	411	393	374	341	315	289	254	225	188	176	151	135	117	107	95	83	47	19	10		
Type	1	3	5	7	9	12	14	16	18	20	23	24	26	27	28	29	30	31	34	37	38	H [m]	
76/4 C5									85	62	38	9											Flow rate Q [m³/h]
151/4 C6											103	101	81	54	44	35	23	10					
231/4 C6															125	111	94	80	68	31			

### TECHNICAL DATA

Type	Voltage (50 Hz) Volt	Max. Motor Rating (kW) P1 P2	S3-% Operation Emerged Motor	Max. Current Ampere	RPM min <sup>-1</sup>	Cable (10 m) H07RN-F-	Fuse min.	Discharge branch PN 6/10	Max. Solid Size (mm)	Weight approx.
25/4 C1	3/PE-230/400	2.40 1.90	30	7.3/ 4.2	1395	° 6 G 1.5	10 A	DN 100	100	63 kg
35/4 C1	3/PE-230/400	3.50 2.65	25	12.0/ 6.9	1424	° 6 G 1.5	10 A	DN 100	100	67 kg
55/4 C5	3/PE-400/690	5.80 4.65	20	10.2/ 5.9	1430	° 10 G 2.5	*16 A	DN 100	100	119 kg
75/4 C5	3/PE-400/690	7.20 5.90	25	12.8/ 7.4	1432	° 10 G 2.5	*20 A	DN 100	100	124 kg
100/4 C5	3/PE-400/690	9.50 7.94	25	17.2/10.0	1444	° 10 G 2.5	*25 A	DN 100	100	138 kg
150/4 C6	3/PE-400/690	15.00 13.20	40	26.7/15.5	1466	10 G 2.5	*35 A	DN 100	100	247 kg
230/4 C6	3/PE-400/690	19.30 17.00	35	34.1/19.8	1460	10 G 2.5	*35 A	DN 100	100	275 kg
300/4 C6	3/PE-400/690	25.50 22.65	25	45.5/26.4	1460	7G6+3x1	*50 A	DN 100	100	296 kg
76/4 C5	3/PE-400/690	8.25 6.70	15	14.2/ 8.2	1409	° 10 G 2.5	*20 A	DN 100	100	123 kg
151/4 C6	3/PE-400/690	17.50 15.30	25	30.6/17.7	1452	10 G 2.5	*35 A	DN 100	100	247 kg
231/4 C6	3/PE-400/690	22.00 19.10	25	37.9/22.0	1446	10 G 2.5	*35 A	DN 100	100	276 kg

° plug-in \*Value for Y/Δ-starting

# JUNG PUMPEN MULTISTREAM SEWAGE PUMPS

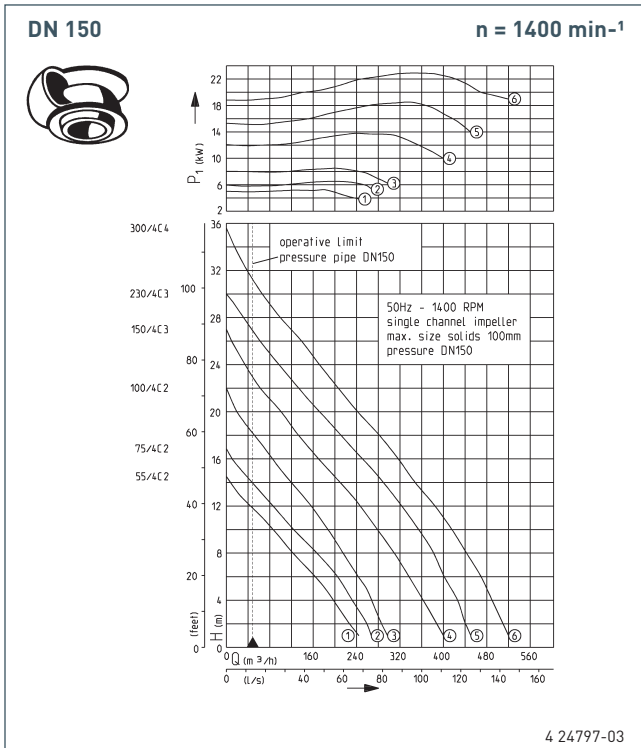

The minimum flow rate in the pressure pipe of  $v = 0,7$  m/s is marked in the Q-H-diagram (operative limit).

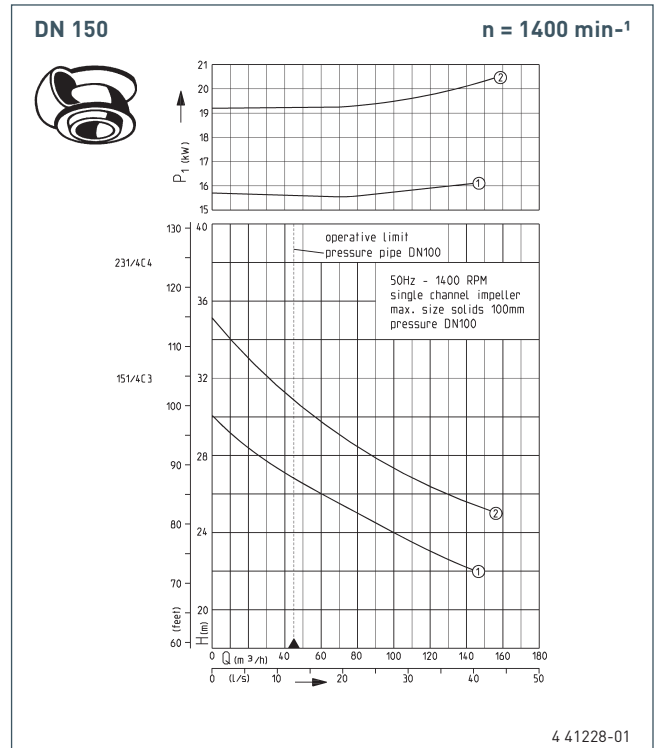

Pump performance is subject to ISO 9906 tolerances

## PERFORMANCE

Type	1	3	5	7	9	11	13	15	17	19	20	21	24	25	27	29	30	31	33	34	H [m]	
55/4 C2	245	214	184	144	105	62	22															Flow rate Q [m³/h]
75/4 C2	270	245	216	185	146	105	64	26														
100/4 C2	300	278	258	229	202	167	130	96	65	33	18											
150/4 C3	400	373	349	325	295	263	227	192	150	116	100	81	34	21								
230/4 C3	455	434	415	394	369	338	308	272	231	191	172	153	98	80	45	17						
300/4 C4	520	500	478	455	426	399	364	334	298	263	242	223	172	157	118	83	66	51	26	15		
Type	1	3	5	7	9	12	14	16	18	20	23	24	26	27	28	29	30	31	34	37	38	H [m]
151/4 C3											119	98	61	44	28	15						Flow rate Q [m³/h]
231/4 C4												136	113	92	75	59	43	7				

## TECHNICAL DATA

Type	Voltage (50 Hz) Volt	Max. Motor Rating (kW) P1 P2	S3-% Operation Emerg Motor	Max. Current Ampere	RPM min-1	Cable (10 m) H07RN-F-	Fuse min.	Discharge branch PN 6/10	Max. Solid Size (mm)	Weight approx.
55/4 C2	3/PE~400/690	5.80 4.65	20	10.2/ 5.9	1430	° 10 G 2.5	*16 A	DN 150	100	125 kg
75/4 C2	3/PE~400/690	7.20 5.90	25	12.8/ 7.4	1432	° 10 G 2.5	*20 A	DN 150	100	131 kg
100/4 C2	3/PE~400/690	9.50 7.94	25	17.2/10.0	1444	° 10 G 2.5	*25 A	DN 150	100	149 kg
150/4 C3	3/PE~400/690	15.00 13.20	40	26.7/15.5	1466	10 G 2.5	*35 A	DN 150	100	268 kg
230/4 C3	3/PE~400/690	19.30 17.00	35	34.1/19.8	1460	10 G 2.5	*35 A	DN 150	100	288 kg
300/4 C4	3/PE~400/690	25.50 22.65	25	45.5/26.4	1460	7G6+3x1	*50 A	DN 150	100	308 kg
151/4 C3	3/PE~400/690	17.50 15.30	25	30.6/17.7	1452	10 G 2.5	*35 A	DN 150	100	269 kg
231/4 C4	3/PE~400/690	22.00 19.10	25	37.9/22.0	1446	10 G 2.5	*35 A	DN 150	100	290 kg

° plug-in \* Value for Y/Δ-starting

# JUNG PUMPEN MULTISTREAM SEWAGE PUMPS

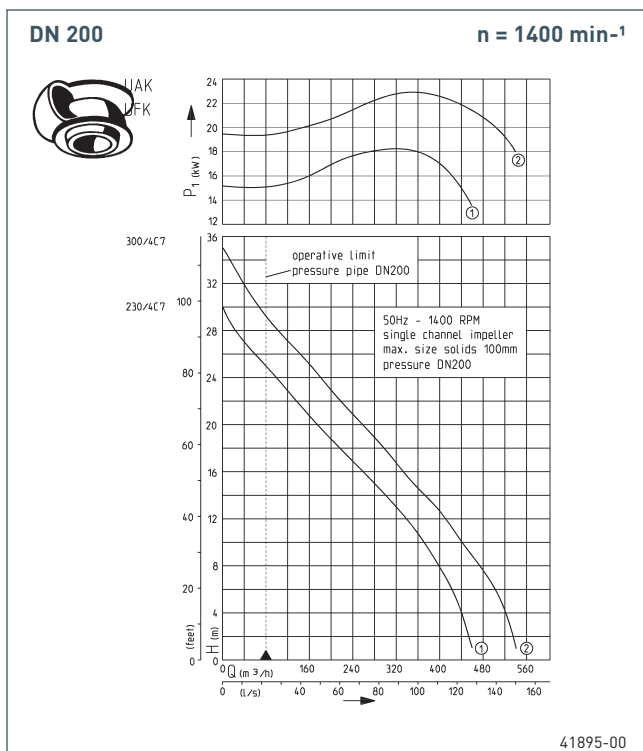

The minimum flow rate in the pressure pipe of  $v = 0,7 \text{ m/s}$  is marked in the Q-H-diagram [operative limit].

## PERFORMANCE

Typ	1	3	5	7	9	11	13	15	17	19	20	21	24	25	27	29	30	31	33	34	H [m]	
230/4 C7	460	443	429	409	387	358	322	282	240	196	177	158	97	78	42	11						Flow rate Q [m <sup>3</sup> /h]
300/4 C7	540	524	509	483	453	427	396	355	318	280	258	238	180	165	126	87	71	54	26	15		

## TECHNICAL DATA

Type	Voltage (50 Hz) Volt	Max. Motor Rating (kW) P <sub>1</sub> P <sub>2</sub>	S3-% Operation Emerg Motor	Max. Current Ampere	RPM min <sup>-1</sup>	Cable (10 m) H07RN-F-	Fuse min.	Discharge branch PN 10	Max. Solid Size (mm)	Weight ca.
230/4 C7	3/PE~400/690	19.3 17.0	35	34.1/19.8	1460	10 G 2.5	*35 A	DN 200	100	295 kg
300/4 C7	3/PE~400/690	25.5 22.65	25	45.5/26.4	1460	7 G 6+3x1	*50 A	DN 200	100	315 kg

\* Value for Y/Δ-starting

# JUNG PUMPEN MULTIFREE

## SEWAGE PUMPS

### APPLICATION

The centrifugal submersible sewage pumps MultiFree are suitable for handling effluent or sewage in municipal and industrial pumping stations as well as in surface water drainage applications. The smaller types are also very successfully as portable units to deal with emergency situations.

The **sewage pumps** are suitable for handling sewage water. In hazardous locations **explosion-proof sewage pumps Ex** have to be used.

MultiFree-sewage pumps are recommended for:

- effluent which contains fibrous matter prone to matting
- effluent which contains solids
- abrasive effluent
- effluent which contains trapped air or gas
- mixed water
- raw effluent
- raw sludge
- surface water
- rainwater

### TECHNICAL DATA

#### Pump

Vertical, single-stage, submersible, pump case with horizontal discharge, vortex impeller and short shaft extension. This provides a longer service life for the ball bearings and the mechanical seals.

#### Bearings

Common shaft for pump and motor, deep groove and inclined ball bearings, grease-packed.

#### Seal

Silicon carbide mechanical seal independent of sense of rotation, oil chamber and artificial carbon mechanical seal or rather SiC mechanical seal (or duplex rotary shaft seal up to size 35) as secondary seal, safe to run dry.

#### Motor

Submersible, enclosure IP68, activation through special purpose plug or control unit, protected by winding thermostats, ex-proof types tested by PTB (German tech. inspection authority), type of protection  II 2 G Ex d IIB T4.

#### Materials

pump, motor case and impeller in GG grey cast iron, corrosion protected shaft (no contact with pumped liquid), flexible rubber sheathed cable

#### Installation

Install pump vertically with guide rail system or pump base. Flange coupling according to DIN, coupling size B or hose tail bend up to 3" possible.



Types of operation: Up to 40°C medium temperature  
Motor submerged: continuous operation S1  
Motor not submerged intermittent operation S3  
(e.g. 15% = 1.5 min operation and 8.5 min pause)

- Connection alternatively in PN 6 or PN 10
- Safe to run dry
- Controllable oil chamber
- Plug type cable connection (10...-75...)
- SiC mechanical seal independent of sense of rotation
- Moisture sealed cable inlet
- Built-in motor protection

#### Scope of supply

Pump acc. to EN 12050 with 10 m cable without plug, without pump base:

- a) as sewage pump
- b) as explosion-proof sewage pump Ex



# JUNG PUMPEN MULTIFREE

## SEWAGE PUMPS

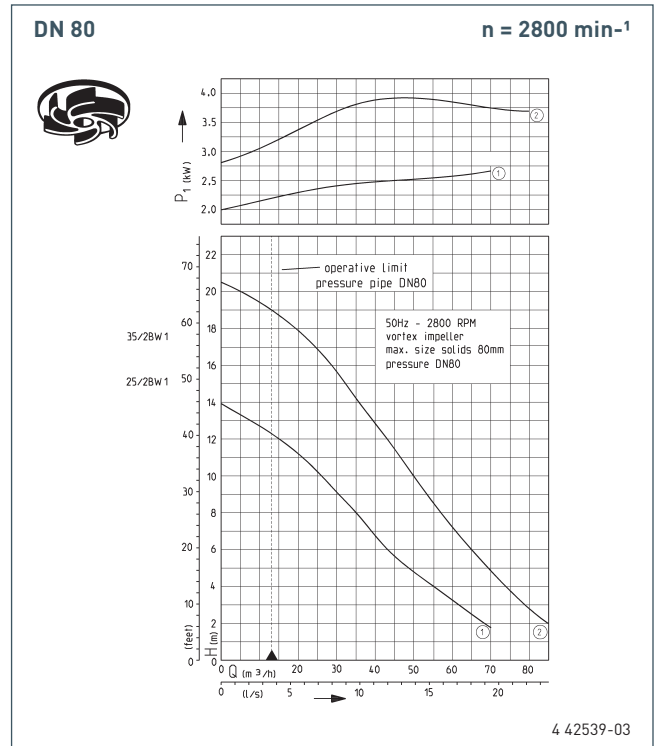
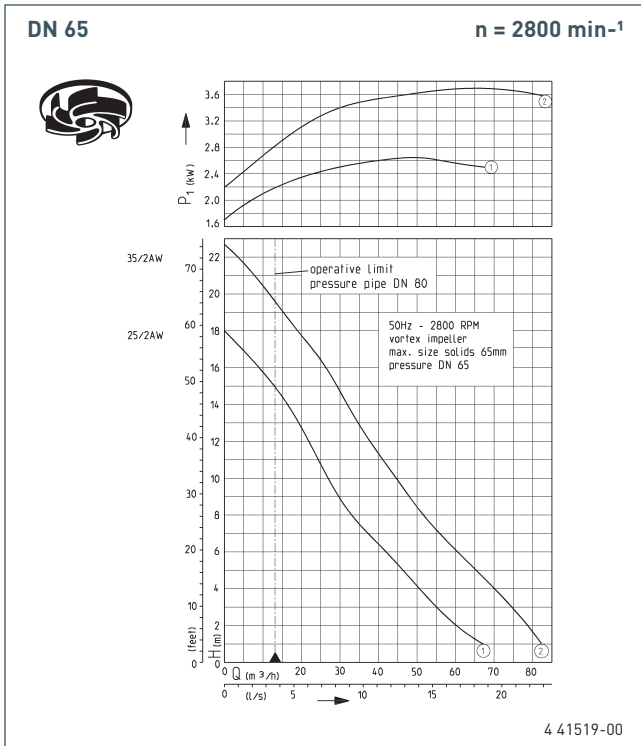

The minimum flow rate in the pressure pipe of  $v = 0,7$  m/s is marked in the Q-H-diagram (operative limit).

Pump performance is subject to ISO 9906 tolerances

### PERFORMANCE

Type	1	2	3	4	5	6	7	8	9	10	12	14	16	18	20	H [m]	
25/2 AW	68	61	55	51	46	41	37	33	30	27	22	16	9	Flow rate Q [m <sup>3</sup> /h]			
35/2 AW	82	80	76	70	65	59	56	52	48	44	38	32	26	19	11		
Type	1	2	3	4	5	6	7	8	9	10	12	14	16			H [m]	
25/2 BW1		68	62	55	49	43	38	35	31	27	15	Flow rate Q [m <sup>3</sup> /h]					
35/2 BW1	90	85	80	74	70	65	60	57	53	50	43	36	29	20	5		

### TECHNICAL DATA

Type	Voltage (50 Hz) Volt	Max. Motor Rating (kW)		S3-% Operation Emerg Motor	Max. Current Ampere	RPM min <sup>-1</sup>	Cable (10 m) H07RN-F-	Fuse min.	Discharge branch PN 6/10	Max. Solid Size (mm)	Weight ca.
		P <sub>1</sub>	P <sub>2</sub>								
25/2 AW	3/PE~230/400	2.90	2.30	35	8.5/4.9	2835	6 G 1.5	10 A	DN 65	65	43 kg
35/2 AW	3/PE~230/400	4.05	3.34	35	12.3/7.1	2884	6 G 1.5	10 A	DN 65	65	46 kg
25/2 BW1	3/PE~230/400	3.27	2.55	25	9.3/5.4	2807	6 G 1.5	10 A	DN 80	80	46 kg
35/2 BW1	3/PE~230/400	4.84	3.95	25	14.2/8.2	2857	6 G 1.5	10 A	DN 80	80	49 kg



# JUNG PUMPEN MULTIFREE

## SEWAGE PUMPS

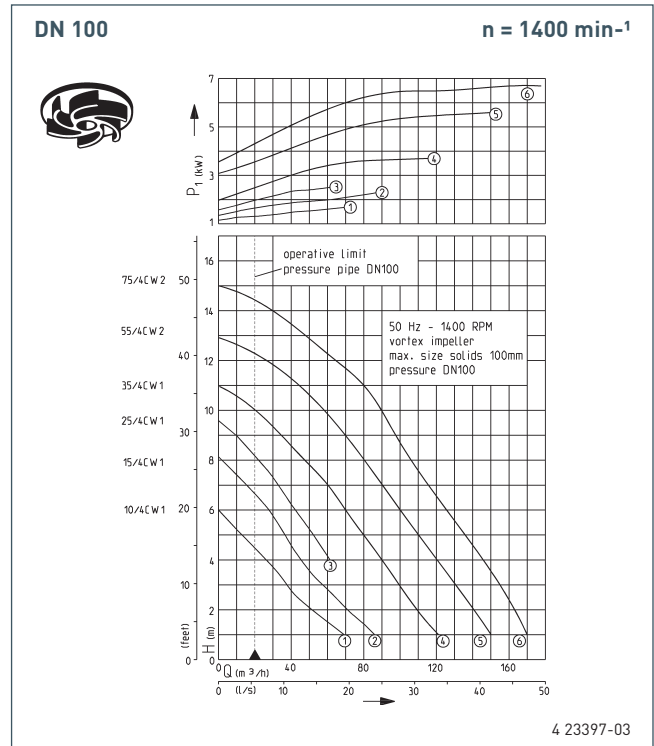
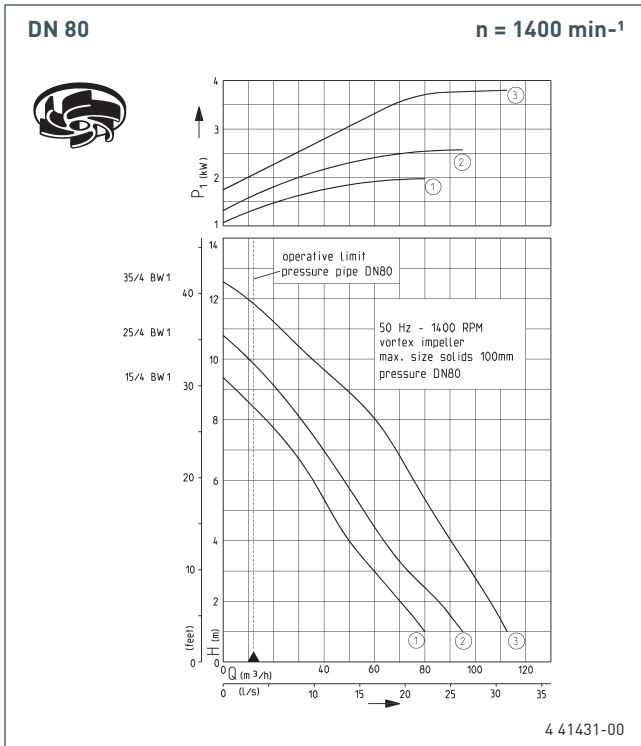

The minimum flow rate in the pressure pipe of  $v = 0,7 \text{ m/s}$  is marked in the Q-H-diagram (operative limit). Pump performance is subject to ISO 9906 tolerances

Pump performance is subject to ISO 9906 tolerances

### PERFORMANCE

Type	1	2	3	4	5	6	7	8	9	10	11	12	15	H [m]	
15/4 BW1	80	70	60	50	42	35	27	18	5					Flow rate Q [m³/h]	
25/4 BW1	95	85	74	64	55	47	40	32	21	9					
35/4 BW1	115	107	98	90	82	75	68	59	49	35	23	10			
Type	1	2	3	4	5	6	7	8	9	10	11	12	13	14	H [m]
10/4 CW1	68	51	37	26	15										Flow rate Q [m³/h]
15/4 CW1	87	71	57	46	37	28	17								
25/4 CW1	-	-	-	61	53	42	32	23							
35/4 CW1	122	112	100	90	81	71	60	48	35	20	3				
55/4 CW2	151	141	131	121	109	100	91	80	69	58	44	24			
75/4 CW2	170	165	155	145	135	125	116	106	98	89	79	66	50	26	

### TECHNICAL DATA

Type	Voltage (50 Hz) Volt	Max. Motor Rating (kW) P <sub>1</sub> P <sub>2</sub>	S3-% Operation Emerged Motor	Max. Current Ampere	RPM min <sup>-1</sup>	Cable (10 m) H07RN-F-	Fuse min.	Discharge branche PN 6/10	Max. Solid Size (mm)	Weight ca.
15/4 BW1	3/PE~230/400	2.20 1.70	35	7.0/4.0	1405	6 G 1.5	10 A	DN 80	80	47 kg
25/4 BW1	3/PE~230/400	2.80 2.10	25	8.2/4.7	1372	6 G 1.5	10 A	DN 80	80	47 kg
35/4 BW1	3/PE~230/400	4.20 3.20	20	13.0/7.8	1404	6 G 1.5	10 A	DN 80	80	51 kg
10/4 CW1	3/PE~230/400	1.80 1.40	40	5.9/3.4	1426	6 G 1.5	10 A	DN 100	100	49 kg
15/4 CW1	3/PE~230/400	2.40 1.90	30	7.3/4.2	1395	6 G 1.5	10 A	DN 100	100	49 kg
25/4 CW1	3/PE~230/400	2.70 2.04	25	7.9/4.6	1376	6 G 1.5	10 A	DN 100	100	49 kg
35/4 CW1	3/PE~230/400	4.20 3.20	20	13.0/7.8	1404	6 G 1.5	10 A	DN 100	100	53 kg
55/4 CW2	3/PE~400/690	6.20 5.00	20	11.0/6.35	1440	10 G 2.5	*16 A	DN 100	100	113 kg
75/4 CW2	3/PE~400/690	7.40 6.10	25	13.1/7.6	1440	10 G 2.5	*20 A	DN 100	100	117 kg

\* Wert für Y/Δ-Anlauf



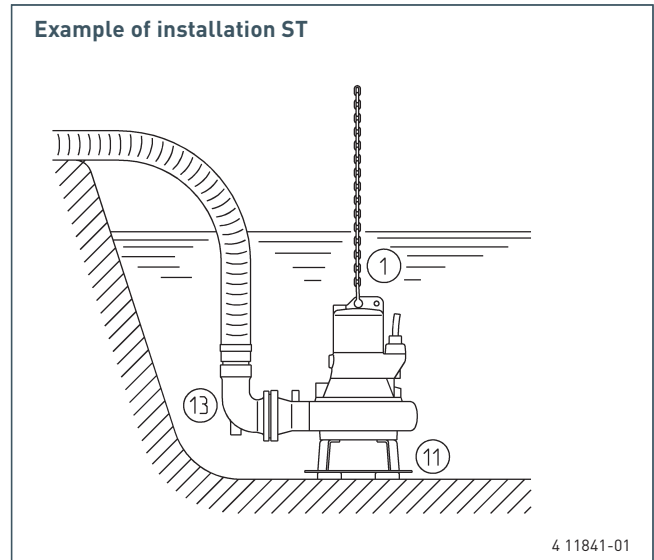
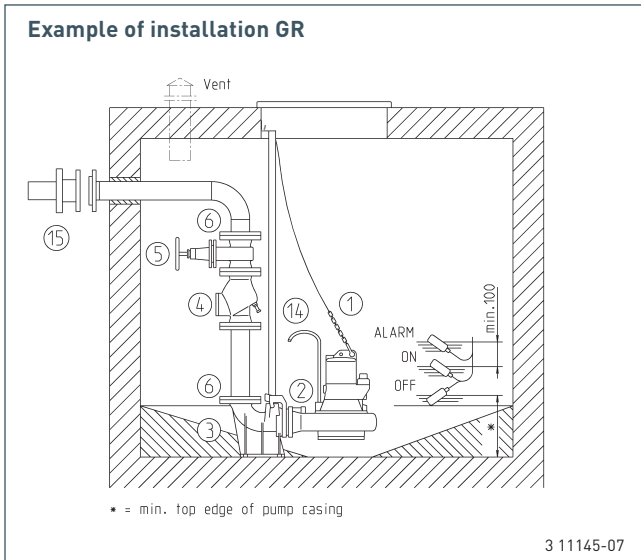

# JUNG PUMPEN MULTISTREAM/MULTIFREE

## ACCESSORIES

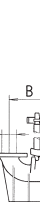

### ACCESSORIES

Selection acc. to the size of casing, e.g. 35/4 B4

Description	Dimensions	Type	Code No.	MultiStream							MultiFree											
				A1	A2	B1	B2	B3	B4	B5	B6	C1	C2	C3	C4	C5	C6	C7	AW	BW1	CW1	CW2
 <b>1 Chain</b> , certified, stainless steel, (EN 818 mod.) 2.5 m 5 rings 5.0 m 8 rings 5.0 m 8 rings <b>Shackle</b> , certified, stainless steel <b>Pump hanging</b> (10/...-100/...)		Load-bearing cap																				
		160 kg	<b>JP45901</b>	•	•	•	•	•	•	•	•	•	•	•	•	•	•	•	•	•	•	
		160 kg	<b>JP45902</b>	•	•	•	•	•	•	•	•	•	•	•	•	•	•	•	•	•	•	•
		320 kg	<b>JP45903</b>	•	•	•	•	•	•	•	•	•	•	•	•	•	•	•	•	•	•	•
		500 kg	<b>JP45904</b>	•	•	•	•	•	•	•	•	•	•	•	•	•	•	•	•	•	•	•
 <b>2 Seal leak control</b>		DKG	<b>JP44900</b>	•	•	•	•	•	•	•	•	•	•	•	•	•	•	•	•	•	•	
		DKG Ex	<b>JP00249</b>	•	•	•	•	•	•	•	•	•	•	•	•	•	•	•	•	•	•	•
 <b>3 Guide rail system PN 10</b> (inkl. accessories)	A	B	H	D/DN																		
	170	226	280	80	GR 65	<b>JP00494</b>	•	•	•	•	•	•	•	•	•	•	•	•	•	•	•	
	170	229	280	80	GR 80	<b>JP00495</b>	•	•	•	•	•	•	•	•	•	•	•	•	•	•	•	
	200	254	310	100	GR 100	<b>JP00496</b>	•	•	•	•	•	•	•	•	•	•	•	•	•	•	•	
	235	254	345	100	GR 101	<b>JP21037</b>	•	•	•	•	•	•	•	•	•	•	•	•	•	•	•	
	260	332	435	150	GR 151	<b>JP00693</b>	•	•	•	•	•	•	•	•	•	•	•	•	•	•	•	
	260	332	435	150	GR 151S	<b>JP09731</b>	•	•	•	•	•	•	•	•	•	•	•	•	•	•	•	•
	305	410	535	200	GR 200S	<b>JP42275</b>	•	•	•	•	•	•	•	•	•	•	•	•	•	•	•	•
 <b>4 Ball check valve*</b> Flange PN 10, DIN 3202, DIN EN 12050-4 (Dimensions see swing-type check valve) <b>Swing-type check valve*</b> Flange PN 10, DIN 3202, DIN EN 12050-4	H	D																				
			DN	PN																		
	260	80	4		without counter weight	R 80	<b>JP00706</b>	•	•	•	•	•	•	•	•	•	•	•	•	•	•	
	300	100	4		without counter weight	R 101	<b>JP00325</b>	♦	♦	♦	♦	♦	♦	♦	♦	♦	♦	♦	♦	♦	♦	
	260	80	4		with counter weight	R 80 G	<b>JP00707</b>	•	•	•	•	•	•	•	•	•	•	•	•	•	•	
	300	100	4		with counter weight	R 100 G	<b>JP00324</b>	♦	♦	♦	♦	♦	♦	♦	♦	♦	♦	♦	♦	♦	♦	
400	150	10			R 150 G	<b>JP00345</b>	•	•	•	•	•	•	•	•	•	•	•	•	•	•		

\* c/w screws and gaskets



• Main ♦ Alternativ proposal

# JUNG PUMPEN MULTISTREAM/MULTIFREE

## ACCESSORIES

### ACCESSORIES

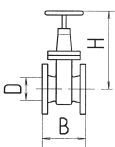
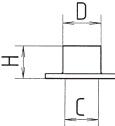
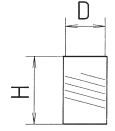
Selection acc. to the size of casing, e35/4 B4

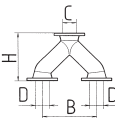
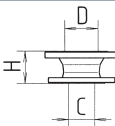
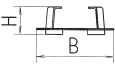
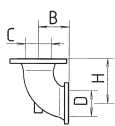
Description	Dimensions	Type	Code No.	MultiStream														MultiFree					
				A1	A2	B1	B2	B3	B4	B5	B6	C1	C2	C3	C4	C5	C6	C7	AW	BW1	CW1	CW2	
 <b>5 Sluice valve*</b> PN 10 nach DIN EN 1171 H B D DN	315 180 80	DN 80	<b>JP00639</b>	•	•	•	•	•	•										•	•			
	345 190 100	DN 100	<b>JP00329</b>	♦	♦	♦	♦	♦	♦	•	•	♦				•	•		♦	♦	•	•	
	430 210 150	DN 150	<b>JP00328</b>									•	•	•									
 <b>6 Spigot flange for steel pipe*</b> H D C Flange DN PN 10  <b>Spigot flange for plastic pipe* F-KS</b> H D C Flange DN PN 10	75 90 80	A 080	<b>JP00686</b>	•	•	•	•	•	•										•	•			
	76 114 80	B 080/100	<b>JP09821</b>	♦	♦	♦	♦	♦	♦										♦	♦			
	100 114 100	C 100	<b>JP00688</b>							•	•				•	•					•	•	
	147 165 150	C 150	<b>JP00703</b>							♦	♦	•	•	•	♦	♦					♦	♦	
	75 90 80			<b>JP00686</b>	•	•	•	•	•	•										•	•		
	85 110 80			<b>JP00687</b>	♦	♦	♦	♦	♦	♦										♦	♦		
	153 110 100			<b>JP08673</b>							•	•	♦				•	•			•	•	
173 160 150			<b>JP08675</b>							♦	♦	•	•	•	♦	♦					♦	♦	
 <b>7 Elastic connection</b> for pipe DN H PN D steel + plastic steel plastic	80 200 4 90	DN 80	<b>JP44768</b>	•	•	•	•	•	•										•	•			
	100 200 4 114	DN 100	<b>JP44774</b>	♦	♦	♦	♦	♦	♦	•	•	♦				•	•		♦	♦	•	•	
	150 350 4 165	DN 150	<b>JP44761</b>									•	•	•									
	100 200 4 110	DN 100	<b>JP44778</b>	♦	♦	♦	♦	♦	♦	•	•	♦				•	•		♦	♦	•	•	
	150 350 4 160	DN 150	<b>JP44779</b>									•	•	•									
 <b>8 Hose band clamp</b> 3" (DN 80) 4" (DN 100) 6" (DN 150)			<b>JP44766</b>	•	•	•	•	•	•										•	•			
			<b>JP44767</b>	♦	♦	♦	♦	♦	♦	•	•	♦				•	•		♦	♦	•	•	
			<b>JP44762</b>									•	•	•									
 <b>9 Flanged Y-pipe*</b> PN 10 H B C D DN 80/100/80 100/100/100 100/150/100 80/100/80 100/100/100 100/150/100 150/150/150	355 390 100 80	80/100/80	<b>JP00448</b>	•	•	•	•	•	•										•	•			
	355 390 100 100	100/100/100	<b>JP00458</b>	♦	♦	♦	♦	♦	♦	•									♦	♦	•		
	355 390 150 100	100/150/100	<b>JP00449</b>								♦										♦		
	355 480 100 80	80/100/80	<b>JP00202</b>	•	•	•	•	•	•											•	•		
	355 480 100 100	100/100/100	<b>JP00203</b>	♦	♦	♦	♦	♦	♦	•	•						•		♦	♦	•	♦	
	355 480 150 100	100/150/100	<b>JP00204</b>								♦	♦									♦	♦	
	355 480 150 150	150/150/150	<b>JP00521</b>										•								♦	♦	
 <b>10 Reducing adapter*</b> nach PN 10 H C D DN DN 100 80 100 200 100 150	100 80 100	Attention: not use in the guide rail area.	<b>JP00498</b>	•	•	•	•	•	•										•	•			
	200 100 150	DN 80/100	<b>JP00510</b>							•	•										•	•	
		DN 100/150																					
 <b>11 Pump pedestal*</b> H B 76 245 76 295 115 280 115 330 145 345 145 390 145 565 145 650	76 245	A 170	<b>JP00681</b>	•																			
	76 295	A 220	<b>JP00682</b>		•															•			
	115 280	B 170	<b>JP00683</b>			•															•		
	115 330	B 220	<b>JP00684</b>				•	•	•													•	
	145 345	C 220	<b>JP11453</b>																			•	
	145 390	C 275	<b>JP00685</b>							•	•	•				•							
	145 565	C 325	<b>JP00701</b>										•									•	
	145 650	C 410	<b>JP00702</b>											•	•	•		•	•				
 <b>12 Flanged socket*</b> H B C/DN (PN10) D/DN (PN6) 130 75 80 65 150 100 80 80 175 120 100 100 250 175 150 150	130 75 80 65	A 80	<b>JP00577</b>	•	•														•				
	150 100 80 80	B 80	<b>JP00578</b>			•	•	•	•	•											•		
	175 120 100 100	C 100	<b>JP00579</b>								•	•									•	•	
	250 175 150 150	C 150	<b>JP00591</b>																				

\* c/w screws and gaskets



• Main ♦ Alternativ proposal

# JUNG PUMPEN MULTISTREAM/MULTIFREE

## ACCESSORIES

### ACCESSORIES

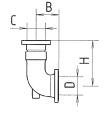
Selection acc. to the size of casing, e.g. 35/4 B4

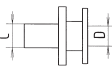
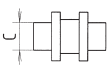
Description	Dimensions	Type	Code No.	MultiStream														MultiFree								
				A1	A2	B1	B2	B3	B4	B5	B6	C1	C2	C3	C4	C5	C6	C7	AW	BW1	CW1	CW2				
 <b>13 Coupling connection*</b> Size „B“ (DIN 14308)	H	B	C	D (DN)																						
	180	75	2 1/2"	65	A	<b>JP00503</b>	•	•																	•	
	200	100	2 1/2"	80	B	<b>JP00504</b>			•	•	•	•	•													
 <b>14 Flushing tube</b>	Typ I	( 10/... bis 35/...)*			<b>JP28221</b>	•	•	•	•	•														•	•	•
	Typ II	( 55/... bis 100/...)*			<b>JP28222</b>				•		•	•					•								•	
	Typ III	(150/... bis 300/...)			<b>JP28223</b>						•			•	•			•	•							
 <b>15 Flange adaptor</b>   <b>Pipe connector</b>	DN 80				<b>JP30062</b>	•	•	•	•	•	•													•	•	
	DN 100				<b>JP30063</b>	◊	◊	◊	◊	◊	◊	◊	•	•				•	•			◊	◊	•	•	
	DN 150				<b>JP30064</b>	◊	◊	◊	◊	◊	◊	◊	◊	•	•	•	•	◊	◊			◊	◊	◊	◊	
	DN 80				<b>JP30065</b>	•	•	•	•	•	•														•	•
	DN 100				<b>JP30066</b>	◊	◊	◊	◊	◊	◊	◊	•	•					•	•			◊	◊	•	•
	DN 150				<b>JP30067</b>	◊	◊	◊	◊	◊	◊	◊	◊	•	•	•	•	◊	◊			◊	◊	◊	◊	
	<b>Inner support sleeve</b> for PE-pipe	DN 80, PE 100, SDR 11				<b>JP30096</b>	•	•	•	•	•	•													•	•
DN 100, PE 100, SDR 11					<b>JP30097</b>								•	•											•	•

\* c/w screws and gaskets

+ Flushing effect from 4 m delivery head (AW, BW1 und CW1)

++ Flushing effect from 6 m delivery head (CW2)

• Main

◊ Alternativ

# JUNG PUMPEN MULTISTREAM

## DIMENSIONS GUIDE RAIL SYSTEM (MM)

For permanent stations, particularly for installations which are subject to routine official safety inspections, this is a neat and low-maintenance solution.

- Easy maintenance - independent of the sump depth.
- No need to release old connections, no troublesome resealing of screw connections needed when putting the pump back into operation.
- No need to empty the sump with another pump in the case of failure or fault in the plant.
- Save time and money on maintenance.

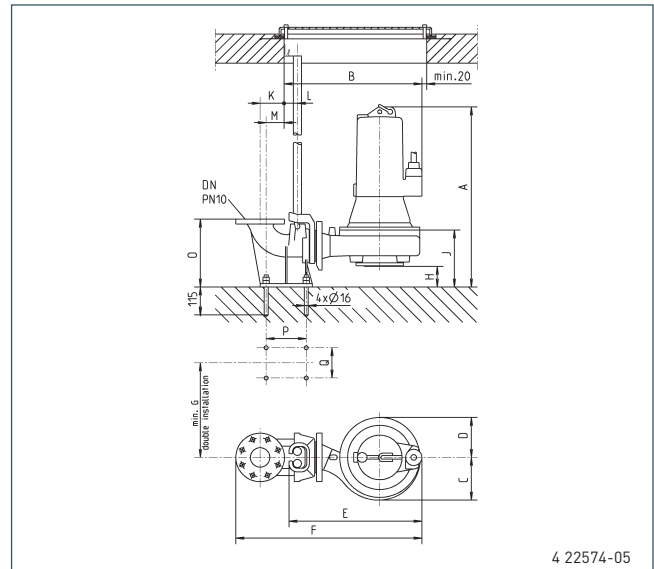

### MULTISTREAM

Type	GR	DN	A	B	C	D	E	F	G	H	J	K	L	M	N	O	P	Q
10/2 A1	65	80	510	460	110	105	435	660	390	108	213	100	55	74	1"	280	165	125
15/2 A1	65	80	510	460	110	105	435	660	390	108	213	100	55	74	1"	280	165	125
25/2 A2	65	80	510	480	130	125	455	680	390	108	220	100	55	74	1"	280	165	125
35/2 A2	65	80	545	480	130	125	455	680	390	108	220	100	55	74	1"	280	165	125
25/2 B1	80	80	520	475	130	110	455	675	390	95	225	100	55	74	1"	280	165	125
35/2 B2	80	80	555	495	145	125	475	695	390	92	225	100	55	74	1"	280	165	125
55/2 B2	80	80	680	525	145	125	510	725	390	92	225	100	55	74	1"	280	165	125
75/2 B5	80	80	685	565	180	165	550	765	390	85	235	100	55	74	1"	280	165	125
100/2 B5	80	80	745	565	180	165	550	765	390	85	235	100	55	74	1"	280	165	125
200/2 B6	101	100	910	680	235	190	660	900	480	155	315	110	55	82	1"	345	175	385
300/2 B6	101	100	1000	680	235	190	660	900	480	155	315	110	55	82	1"	345	175	385
10/4 B1	80	80	520	475	130	110	455	675	390	95	225	100	55	74	1"	280	165	125
15/4 B3	80	80	520	490	145	125	470	690	390	95	225	100	55	74	1"	280	165	125
25/4 B4	80	80	520	570	190	160	545	770	390	85	225	100	55	74	1"	280	165	125
35/4 B4	80	80	555	570	190	160	545	770	390	85	225	100	55	74	1"	280	165	125
55/4 B6	101	100	765	670	235	190	650	890	480	155	315	110	55	82	1"	345	175	385
75/4 B6	101	100	765	670	235	190	650	890	480	155	315	110	55	82	1"	345	175	385
25/4 C1	100	100	565	570	185	160	550	790	390	95	270	110	55	82	1"	310	175	150
35/4 C1	100	100	600	570	185	160	550	790	390	95	270	110	55	82	1"	310	175	150
55/4 C5	101	100	765	645	230	180	625	865	480	125	315	110	55	82	1"	345	175	385
75/4 C5	101	100	765	645	230	180	625	865	480	125	315	110	55	82	1"	345	175	385
100/4 C5	101	100	825	645	230	180	625	865	480	125	315	110	55	82	1"	345	175	385
150/4 C6	101	100	910	755	290	250	735	975	580	105	315	110	55	82	1"	345	175	385
230/4 C6	101	100	1000	755	290	250	735	975	580	105	315	110	55	82	1"	345	175	385
300/4 C6	101	100	1000	755	290	250	735	975	580	105	315	110	55	82	1"	345	175	385
76/4 C5	101	100	765	645	230	180	625	865	480	125	315	110	55	82	1"	345	175	385
151/4 C6	101	100	910	755	290	250	735	975	580	105	315	110	55	82	1"	345	175	385
231/4 C6	101	100	1000	755	290	250	735	975	580	105	315	110	55	82	1"	345	175	385
55/4 C2	151S	150	790	770	260	200	740	1055	480	150	340	145	80	122	1 1/2"	435	260	385
75/4 C2	151S	150	790	770	260	200	740	1055	480	150	340	145	80	122	1 1/2"	435	260	385
100/4 C2	151S	150	850	770	260	200	740	1055	480	150	340	145	80	122	1 1/2"	435	260	385
150/4 C3	151	150	935	885	325	260	855	1175	630	130	340	145	80	122	1 1/2"	435	260	385
230/4 C3	151	150	1025	885	325	260	855	1175	630	130	340	145	80	122	1 1/2"	435	260	385
300/4 C4	151	150	1025	885	325	260	855	1175	630	130	340	145	80	122	1 1/2"	435	260	385
151/4 C3	151	150	935	885	325	260	855	1175	630	130	340	145	80	122	1 1/2"	435	260	385
231/4 C4	151	150	1025	885	325	260	855	1175	630	130	340	145	80	122	1 1/2"	435	260	385
230/4 C7	200S	200	1070	935	325	260	905	1305	630	175	385	200	80	193	1 1/2"	535	350	400
300/4 C7	200S	200	1070	935	325	260	905	1305	630	175	385	200	80	193	1 1/2"	535	350	400

# JUNG PUMPEN MULTISTREAM

## DIMENSIONS PUMP BASE (MM)

For transportable application and mobile use on various sites, a pump with base and hose connection is suitable.

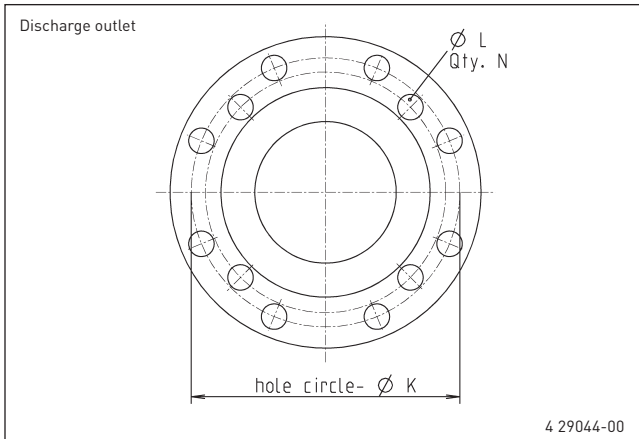

Dimensions of hose tail bend, coupling connection or flanged outlet bend see accessories!

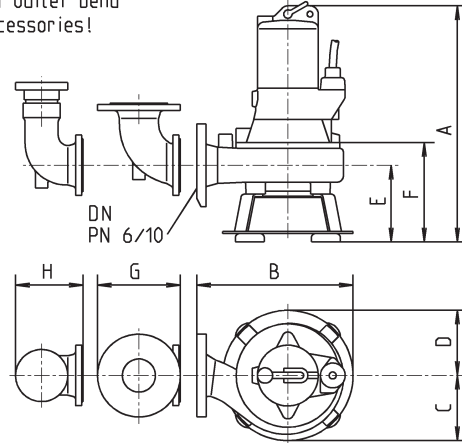

### MULTISTREAM

Type	DN	A	B	C	D	E	F	G	H	K	L	N
10/2 A1	65	475	325	110	105	135	175	175	140	130/145	14/18	4
15/2 A1	65	475	325	110	105	135	175	175	140	130/145	14/18	4
25/2 A2	65	475	345	135	135	135	185	175	140	130/145	14/18	4
35/2 A2	65	510	345	135	135	135	185	175	140	130/145	14/18	4
25/2 B1	80	530	340	135	135	185	240	200	165	150/160	18	4/8
35/2 B2	80	570	380	145	135	185	240	200	165	150/160	18	4/8
55/2 B2	80	700	395	145	135	185	240	200	165	150/160	18	4/8
75/2 B5	80	725	460	195	195	215	280	200	165	150/160	18	4/8
100/2 B5	80	785	460	195	195	215	280	200	165	150/160	18	4/8
200/2 B6	100	885	535	235	195	210	290	230	-	170/180	18	4/8
300/2 B6	100	975	535	235	195	210	290	230	-	170/180	18	4/8
10/4 B1	80	530	340	135	135	185	240	200	165	150/160	18	4/8
15/4 B3	80	535	380	160	160	185	240	200	165	150/160	18	4/8
25/4 B4	80	535	440	190	160	185	240	200	165	150/160	18	4/8
35/4 B4	80	570	440	190	160	185	240	200	165	150/160	18	4/8
55/4 B6	100	740	520	235	195	210	290	230	-	170/180	18	4/8
75/4 B6	100	740	520	235	195	210	290	230	-	170/180	18	4/8
25/4 C1	100	600	450	195	195	235	305	230	-	170/180	18	4/8
35/4 C1	100	635	450	195	195	235	305	230	-	170/180	18	4/8
55/4 C5	100	775	480	230	195	240	320	230	-	170/180	18	4/8
75/4 C5	100	775	480	230	195	240	320	230	-	170/180	18	4/8
100/4 C5	100	835	480	230	195	240	320	230	-	170/180	18	4/8
150/4 C6	100	925	610	290	250	250	330	230	-	170/180	18	4/8
230/4 C6	100	1015	610	290	250	250	330	230	-	170/180	18	4/8
300/4 C6	100	1015	610	290	250	250	330	230	-	170/180	18	4/8
76/4 C5	100	775	480	230	195	240	320	230	-	170/180	18	4/8
151/4 C6	100	925	610	290	250	250	330	230	-	170/180	18	4/8
231/4 C6	100	1015	610	290	250	250	330	230	-	170/180	18	4/8
55/4 C2	150	770	580	260	215	240	320	320	-	225/240	18/22	8
75/4 C2	150	770	580	260	215	240	320	320	-	225/240	18/22	8
100/4 C2	150	830	580	260	215	240	320	320	-	225/240	18/22	8
150/4 C3	150	925	695	325	260	250	330	320	-	225/240	18/22	8
230/4 C3	150	1015	695	325	260	250	330	320	-	225/240	18/22	8
300/4 C4	150	1015	695	325	260	250	330	320	-	225/240	18/22	8
151/4 C3	150	925	695	325	260	250	330	320	-	225/240	18/22	8
231/4 C4	150	1015	695	325	260	250	330	320	-	225/240	18/22	8
230/4 C7	200	1015	725	325	260	250	330	-	-	295	22	8
300/4 C7	200	1015	725	325	260	250	330	-	-	295	22	8

# JUNG PUMPEN MULTIFREE DIMENSIONS GUIDE RAIL SYSTEM (MM)

For permanent stations, particularly for installations which are subject to routine official safety inspections, this is a neat and low-maintenance solution.

- Easy maintenance - independent of the sump depth.
- No need to release old connections, no troublesome resealing of screw connections needed when putting the pump back into operation.
- No need to empty the sump with another pump in the case of failure or fault in the plant.
- Save time and money on maintenance.

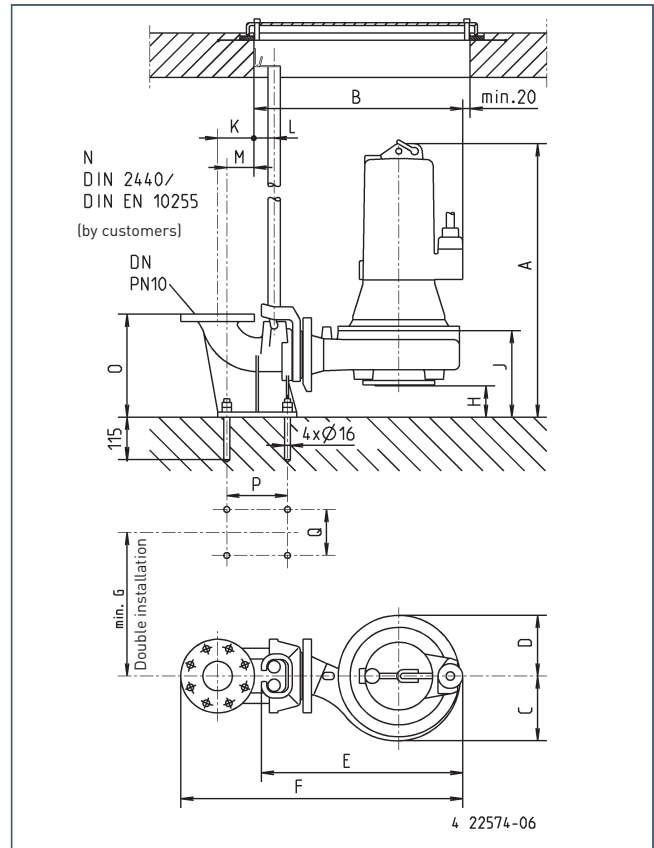

## MULTIFREE

Type	GR	DN	A	B	C	D	E	F	G	H	J	K	L	M	N	O	P	Q
<b>25/2 AW</b>	65	80	520	490	130	130	470	690	390	115	220	100	55	74	1"	280	165	125
<b>35/2 AW</b>	65	80	555	490	130	130	470	690	390	115	220	100	55	74	1"	280	165	125
<b>25/2 BW1</b>	80	80	535	490	140	140	485	705	390	85	235	100	55	74	1"	280	165	125
<b>35/2 BW1</b>	80	80	570	490	140	140	485	705	390	85	235	100	55	74	1"	280	165	125
<b>15/4 BW1</b>	80	80	530	505	140	140	485	705	390	85	235	100	55	74	1"	280	165	125
<b>25/4 BW1</b>	80	80	535	505	140	140	485	705	390	85	235	100	55	74	1"	280	165	125
<b>35/4 BW1</b>	80	80	570	505	140	140	485	705	390	85	235	100	55	74	1"	280	165	125
<b>10/4 CW1</b>	100	100	565	540	140	140	520	760	390	120	270	110	55	82	1"	310	175	150
<b>15/4 CW1</b>	100	100	565	540	140	140	520	760	390	120	270	110	55	82	1"	310	175	150
<b>25/4 CW1</b>	100	100	565	540	140	140	520	760	390	120	270	110	55	82	1"	310	175	150
<b>35/4 CW1</b>	100	100	600	540	140	140	520	760	390	120	270	110	55	82	1"	310	175	150
<b>55/4 CW2</b>	101	100	775	635	195	195	620	860	480	135	330	110	55	82	1"	345	175	385
<b>75/4 CW2</b>	101	100	775	635	195	195	620	860	480	135	330	110	55	82	1"	345	175	385

# JUNG PUMPEN MULTIFREE

## DIMENSIONS PUMP BASE (MM)

For transportable application and mobile use on various sites, a pump with base and hose connection is suitable.

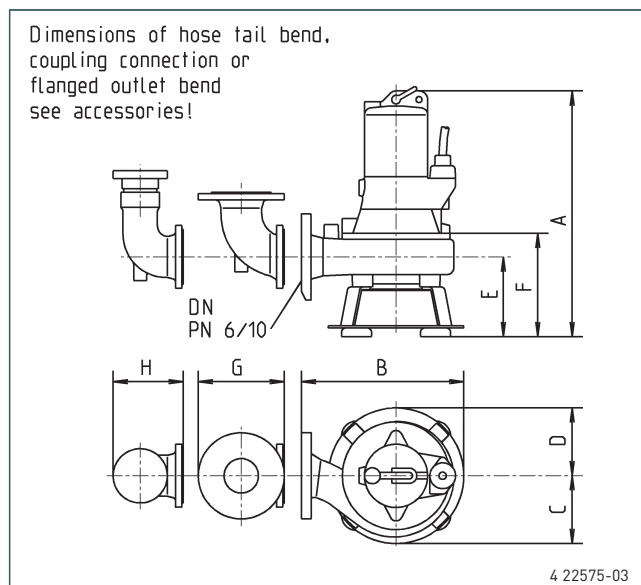
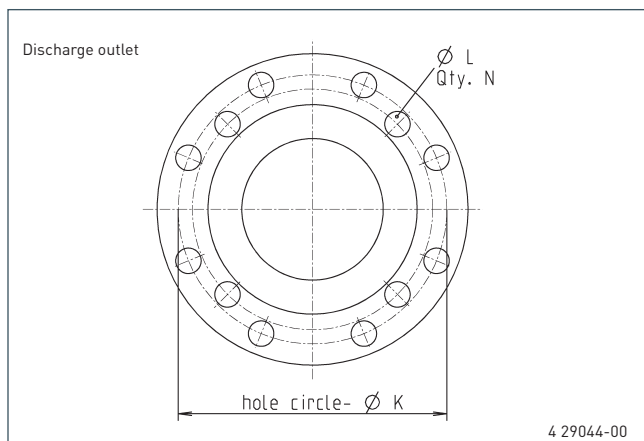

### MULTIFREE

Type	DN	A	B	C	D	E	F	G	H	K	L	N
<b>25/2 AW</b>	65	500	360	135	135	155	215	175	140	130/145	14/18	4
<b>35/2 AW</b>	65	535	360	135	135	155	215	175	140	130/145	14/18	4
<b>25/2 BW1</b>	80	550	375	140	140	205	265	200	165	150/160	18	4/8
<b>35/2 BW1</b>	80	585	375	140	140	205	265	200	165	150/160	18	4/8
<b>15/4 BW1</b>	80	550	375	140	140	205	265	200	165	150/160	18	4/8
<b>25/4 BW1</b>	80	550	375	140	140	205	265	200	165	150/160	18	4/8
<b>35/4 BW1</b>	80	585	375	140	140	205	265	200	165	150/160	18	4/8
<b>10/4 CW1</b>	100	585	415	165	165	220	290	230	-	170/180	18	4/8
<b>15/4 CW1</b>	100	585	415	165	165	220	290	230	-	170/180	18	4/8
<b>25/4 CW1</b>	100	585	415	165	165	220	290	230	-	170/180	18	4/8
<b>35/4 CW1</b>	100	620	415	165	165	220	290	230	-	170/180	18	4/8
<b>55/4 CW2</b>	100	785	520	215	215	245	335	230	-	170/180	18	4/8
<b>75/4 CW2</b>	100	785	520	215	215	245	335	230	-	170/180	18	4/8



# JUNG PUMPEN MULTISTREAM

## ASSIGNMENT OF CONTROL UNITS

MultiStream Sewage pump without ex-proof		Single unit		Duplex unit		MultiStream Sewage pump with ex-proof		Single unit		Duplex unit	
Type	Code No.	Control unit without float switch	Code No.	Control unit without float switch	Code No.	Type	Code No.	Control unit without float switch	Code No.	Control unit without float switch	Code No.
10/2 A1	JP09615	AD 25	JP00310	BD 25	JP45737	10/2 A1	JP09628	AD 25 Ex	JP09683	BD 25 Ex	JP09681
15/2 A1	JP09616	AD 25	JP00310	BD 25	JP45737	15/2 A1	JP09629	AD 25 Ex	JP09683	BD 25 Ex	JP09681
25/2 A2	JP09617	AD 46	JP14353	BD 46	JP45739	25/2 A2	JP09630	AD 46 Ex	JP14355	BD 46 Ex	JP14360
35/2 A2	JP09651	AD 610	JP14354	BD 610	JP45741	35/2 A2	JP09653	AD 610 Ex	JP14356	BD 610 Ex	JP14361
25/2 B1	JP09618	AD 46	JP14353	BD 46	JP45739	25/2 B1	JP09631	AD 46 Ex	JP14355	BD 46 Ex	JP14360
35/2 B2	JP09652	AD 610	JP14354	BD 610	JP45741	35/2 B2	JP09654	AD 610 Ex	JP14356	BD 610 Ex	JP14361
55/2 B2	JP09663	AS 46*	JP14406	BS 46*	JP14411	55/2 B2	JP09664	AS 46*	JP14406	BS 46*	JP14411
75/2 B5	JP00485	AS 610	JP14407	BS 610	JP14412	75/2 B5	JP09665	AS 610	JP14407	BS 610	JP14412
100/2 B5	JP09740	AS 1016	JP14408	BS 1016	JP14413	100/2 B5	JP09741	AS 1016	JP14408	BS 1016	JP14413
200/2 B6	JP00492	AS 1624	JP14409	BS 1624	JP14414	200/2 B6	JP00472	AS 1624	JP14409	BS 1624	JP14414
300/2 B6	JP00471	AS 2440	JP14410	BS 2440	JP14415	300/2 B6	JP00473	AS 2440	JP14410	BS 2440	JP14415
10/4 B1	JP09620	AD 25	JP00310	BD 25	JP45737	10/4 B1	JP09633	AD 25 Ex	JP09683	BD 25 Ex	JP09681
15/4 B3	JP09622	AD 25	JP00310	BD 25	JP45737	15/4 B3	JP09635	AD 25 Ex	JP09683	BD 25 Ex	JP09681
25/4 B4	JP09623	AD 46	JP14353	BD 46	JP45739	25/4 B4	JP09636	AD 46 Ex	JP14355	BD 46 Ex	JP14360
35/4 B4	JP09647	AD 610	JP14354	BD 610	JP45741	35/4 B4	JP09649	AD 610 Ex	JP14356	BD 610 Ex	JP14361
55/4 B6	JP00486	AS 610*	JP14407	BS 610*	JP14412	55/4 B6	JP09666	AS 610*	JP14407	BS 610*	JP14412
75/4 B6	JP00489	AS 610	JP14407	BS 610	JP14412	75/4 B6	JP09667	AS 610	JP14407	BS 610	JP14412
25/4 C1	JP09624	AD 46	JP14353	BD 46	JP45739	25/4 C1	JP09637	AD 46 Ex	JP14355	BD 46 Ex	JP14360
35/4 C1	JP09648	AD 610	JP14354	BD 610	JP45741	35/4 C1	JP09650	AD 610 Ex	JP14356	BD 610 Ex	JP14361
55/4 C5	JP09901	AS 610*	JP14407	BS 610*	JP14412	55/4 C5	JP09902	AS 610*	JP14407	BS 610*	JP14412
75/4 C5	JP09904	AS 610	JP14407	BS 610	JP14412	75/4 C5	JP09905	AS 610	JP14407	BS 610	JP14412
100/4 C5	JP09275	AS 1016	JP14408	BS 1016	JP14413	100/4 C5	JP09276	AS 1016	JP14408	BS 1016	JP14413
150/4 C6	JP09882	AS 1624	JP14409	BS 1624	JP14414	150/4 C6	JP09883	AS 1624	JP14409	BS 1624	JP14414
230/4 C6	JP09885	AS 1624	JP14409	BS 1624	JP14414	230/4 C6	JP09886	AS 1624	JP14409	BS 1624	JP14414
300/4 C6	JP09888	AS 2440	JP14410	BS 2440	JP14415	300/4 C6	JP09889	AS 2440	JP14410	BS 2440	JP14415
76/4 C5	JP09398	AS 610	JP14407	BS 610	JP14412	76/4 C5	JP09399	AS 610	JP14407	BS 610	JP14412
151/4 C6	JP09400	AS 1624	JP14409	BS 1624	JP14414	151/4 C6	JP09401	AS 1624	JP14409	BS 1624	JP14414
231/4 C6	JP09402	AS 1624	JP14409	BS 1624	JP14414	231/4 C6	JP09403	AS 1624	JP14409	BS 1624	JP14414
55/4 C2	JP00487	AS 610*	JP14407	BS 610*	JP14412	55/4 C2	JP09668	AS 610*	JP14407	BS 610*	JP14412
75/4 C2	JP00490	AS 610	JP14407	BS 610	JP14412	75/4 C2	JP09669	AS 610	JP14407	BS 610	JP14412
100/4 C2	JP09678	AS 1016	JP14408	BS 1016	JP14413	100/4 C2	JP09679	AS 1016	JP14408	BS 1016	JP14413
150/4 C3	JP00491	AS 1624	JP14409	BS 1624	JP14414	150/4 C3	JP00474	AS 1624	JP14409	BS 1624	JP14414
230/4 C3	JP00883	AS 1624	JP14409	BS 1624	JP14414	230/4 C3	JP00884	AS 1624	JP14409	BS 1624	JP14414
300/4 C4	JP00493	AS 2440	JP14410	BS 2440	JP14415	300/4 C4	JP00475	AS 2440	JP14410	BS 2440	JP14415
151/4 C3	JP09445	AS 1624	JP14409	BS 1624	JP14414	151/4 C3	JP09446	AS 1624	JP14409	BS 1624	JP14414
231/4 C4	JP09447	AS 1624	JP14409	BS 1624	JP14414	231/4 C4	JP09448	AS 1624	JP14409	BS 1624	JP14414
230/4 C7	JP09392	AS 1624	JP14409	BS 1624	JP14414	230/4 C7	JP09393	AS 1624	JP14409	BS 1624	JP14414
300/4 C7	JP09394	AS 2440	JP14410	BS 2440	JP14415	300/4 C7	JP09395	AS 2440	JP14410	BS 2440	JP14415

\*In connection with 55/... a control unit with direct start is required.

For Ex-proof pumps please consider the dry run protection.

**Additional requirements, see technical data control units**

# JUNG PUMPEN MULTIFREE

## ASSIGNMENT OF CONTROL UNITS

MultiStream Sewage pump without ex-proof		Single unit		Duplex unit		MultiStream Sewage pump with ex-proof		Single unit		Duplex unit	
Type	Code No.	Control unit without float switch	Code No.	Control unit without float switch	Code No.	Type	Code No.	Control unit without float switch	Code No.	Control unit without float switch	Code No.
25/2 AW	<b>JP09149</b>	AD 46	<b>JP14353</b>	BD 46	<b>JP45739</b>	25/2 AW	<b>JP09150</b>	AD 46 Ex	<b>JP14355</b>	BD 46 Ex	<b>JP14360</b>
35/2 AW	<b>JP09151</b>	AD 610	<b>JP14354</b>	BD 610	<b>JP45741</b>	35/2 AW	<b>JP09152</b>	AD 610 Ex	<b>JP14356</b>	BD 610 Ex	<b>JP14361</b>
25/2 BW1	<b>JP09498</b>	AD 46	<b>JP14353</b>	BD 46	<b>JP45739</b>	25/2 BW1	<b>JP09499</b>	AD 46 Ex	<b>JP14355</b>	BD 46 Ex	<b>JP14360</b>
35/2 BW1	<b>JP09500</b>	AD 610	<b>JP14354</b>	BD 610	<b>JP45741</b>	35/2 BW1	<b>JP09501</b>	AD 610 Ex	<b>JP14356</b>	BD 610 Ex	<b>JP14361</b>
15/4 BW1	<b>JP09455</b>	AD 46	<b>JP14353</b>	BD 46	<b>JP45739</b>	15/4 BW1	<b>JP09458</b>	AD 46 Ex	<b>JP14355</b>	BD 46 Ex	<b>JP14360</b>
25/4 BW1	<b>JP09456</b>	AD 46	<b>JP14353</b>	BD 46	<b>JP45739</b>	25/4 BW1	<b>JP09459</b>	AD 46 Ex	<b>JP14355</b>	BD 46 Ex	<b>JP14360</b>
35/4 BW1	<b>JP09457</b>	AD 610	<b>JP14354</b>	BD 610	<b>JP45741</b>	35/4 BW1	<b>JP09460</b>	AD 610 Ex	<b>JP14356</b>	BD 610 Ex	<b>JP14361</b>
10/4 CW1	<b>JP09610</b>	AD 25	<b>JP00310</b>	BD 25	<b>JP45737</b>	10/4 CW1	<b>JP09609</b>	AD 25 Ex	<b>JP09683</b>	BD 25 Ex	<b>JP09681</b>
15/4 CW1	<b>JP09612</b>	AD 46	<b>JP14353</b>	BD 46	<b>JP45739</b>	15/4 CW1	<b>JP09611</b>	AD 46 Ex	<b>JP14355</b>	BD 46 Ex	<b>JP14360</b>
25/4 CW1	<b>JP09655</b>	AD 46	<b>JP14353</b>	BD 46	<b>JP45739</b>	25/4 CW1	<b>JP09656</b>	AD 46 Ex	<b>JP14355</b>	BD 46 Ex	<b>JP14360</b>
35/4 CW1	<b>JP09858</b>	AD 610	<b>JP14354</b>	BD 610	<b>JP45741</b>	35/4 CW1	<b>JP09859</b>	AD 610 Ex	<b>JP14356</b>	BD 610 Ex	<b>JP14361</b>
55/4 CW2	<b>JP09702</b>	AS 610*	<b>JP14407</b>	BS 610*	<b>JP14412</b>	55/4 CW2	<b>JP09704</b>	AS 610*	<b>JP14407</b>	BS 610*	<b>JP14412</b>
75/4 CW2	<b>JP09703</b>	AS 610	<b>JP14407</b>	BS 610	<b>JP14412</b>	75/4 CW2	<b>JP09705</b>	AS 610	<b>JP14407</b>	BS 610	<b>JP14412</b>

\*In connection with 55/... a control unit with direct start is required.

For Ex-proof pumps please consider the dry run protection.

**Additional requirements, see technical data control units**

# JUNG PUMPEN

## SEWAGE PUMPS

### FLUSHING TUBE

Especially in connection with sumps designed by customers, where the shape of the collecting tank is not always ideal, a flushing tube offers the facility to reduce deposits at the sump wall and the formation of surface scums. The flushing tube is mounted instead of the ventilation screw. The special arrangement prevents the flushing tube from blocking and increases the operational reliability.



### SEAL LEAK DETECTOR

The seal leak detector is used to monitor the sealing of the oil chamber between the motor and the hydraulic section of the pumps. If ingress of water into the oil chamber occurs an integrated buzzer is activated.



### DISCHARGE CONNECTION COMBI. PN 6 / PN 10

Thanks to the discharge connection combination PN 6 / PN 10 on all MultiStream- und MultiFree sewage pumps an universal connection to existing pipe systems is very simple. If the existing connection does not comply with the standard dimensions of DIN 1092, connection adapters for several installation situations can be obtained on request.

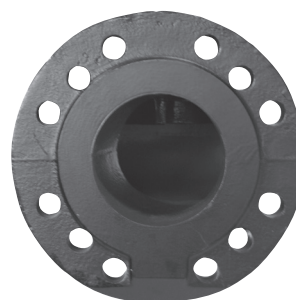

Nominal diameter	Hole centre line diameter-Ø		Number of bolts		Bolt size	
	PN 6	PN 10	PN 6	PN 10	PN 6	PN 10
DN 65	130	145	4	4	M 12	M 16
DN 80	150	160	4	8	M 16	M 16
DN 100	170	180	4	8	M 16	M 16
DN 150	225	240	8	8	M 16	M 20
DN 200	-	295	-	8	-	M 20

# JUNG PUMPEN

## SEWAGE PUMPS

### ADJUSTABLE AXIAL GAP (MULTISTREAM)

In order to ensure optimum efficiency of a pump with channel type hydraulics over a long running period, our pumps have the possibility of adjusting the gap between the impeller and the wear ring or spiral housing by turning a central screw and thereby achieve the optimum setting. This adjustment can be carried out during a normal maintenance operation. It brings the additional advantage of a significant reduction in the possibility of a blockage occurring. Should, nevertheless, solid particle become deposited in the gap, the grooves located in the axial gap area facilitate these being transported away and reduce even further the risk of blockage.

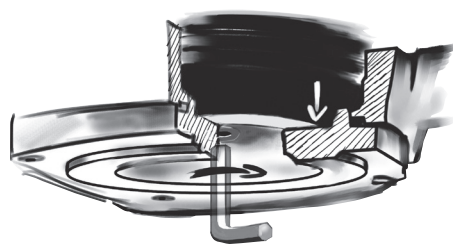

### CERAMIC ANTI-WEAR COATING

Channel type impellers have a larger contact area with the medium being pumped than vortex impellers. This means that they are more exposed to wear caused by abrasive liquids. An optimum coating with liquid ceramic can protect the impeller over a long period of time.

In addition a free solids passage of up to 100 mm is a further assurance of blockage free pumping.

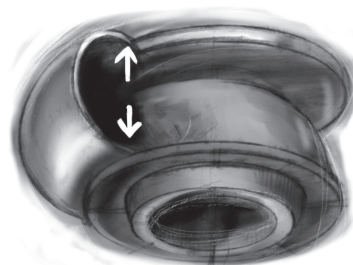

### MOISTURE SEALED CABLE INLET

To protect the motorcasing from water intake through the power cable the separate cores are bared and spilled with a special resin. Only this expensive method guarantees a lasting moisture consistency.

