

NOCCHI MULTINOX-A

MULTI-CELL SELF-PRIMING CENTRIFUGAL PUMPS



RUGGED AND RESISTANT, SELF-PRIMING, OPTIMAL SUCTION CAPACITY, SPECIAL BRASS VALVE, PATENTED FOR CLOSURE DURING PRIMING PHASE

MULTINOX-A horizontal multi-stage self-priming centrifugal pumps are ideal for reaching significant pressure and flow rates with low noise operation and minimal power consumption.

MOTOR

- Closed, ventilated from exterior.
- Protection rating IP 44.
- Insulation class F.
- Single phase power supply with permanently activated capacitor and thermal cutout protection incorporated in the motor winding.
- Three phase power supply with external protection to be fitted by the user.
- Rotation speed 2850 rpm.
- Continuous duty.

APPLICATIONS

- Lifting and distribution of water in domestic systems, with continuous or intermittent duty.
- Pressure booster systems.
- Washing, garden irrigation, fountains.

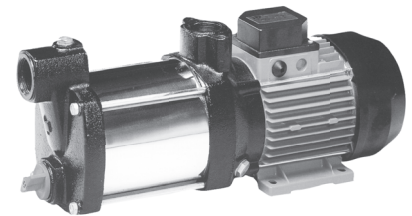

APPLICATION DATA

- Type of liquid: clean water without suspended solid bodies or abrasive material.
- Maximum liquid temperature: 50°C.
- Maximum recommended suction height: 8 m with foot valve.
- Maximum operating pressure: 9 bar.

TABLE OF MATERIALS

Component	Material
1 Casing (pump body)	Stainless steel X5 CrNi 1810 (AISI 304)
2 Suction flange	Cast iron EN GJL 200 (ex G20)
3 Impellers	Technopolymer with shim ring in stainless steel X5 CrNi 1810 (AISI 304)
4 Diffusers	Technopolymer
5 Shaft (hydraulic section)	Stainless steel X5 CrNi 1810 (AISI 304)
6 Mechanical gasket	Graphite
7 Counterface	Ceramic
8 Seals	NBR 70 shore
9 Delivery flange Motor bracket	Cast iron EN GJL 200 (ex G20)

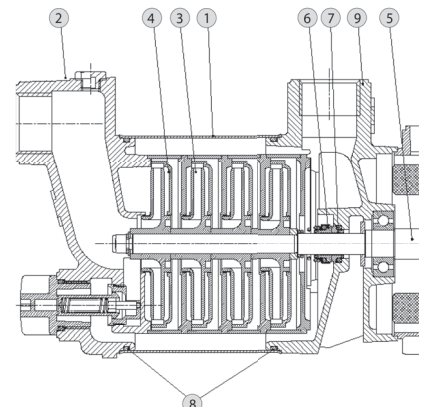

NOCCHI MULTINOX-A

MULTI-CELL SELF-PRIMING CENTRIFUGAL PUMPS

HYDRAULIC PERFORMANCE

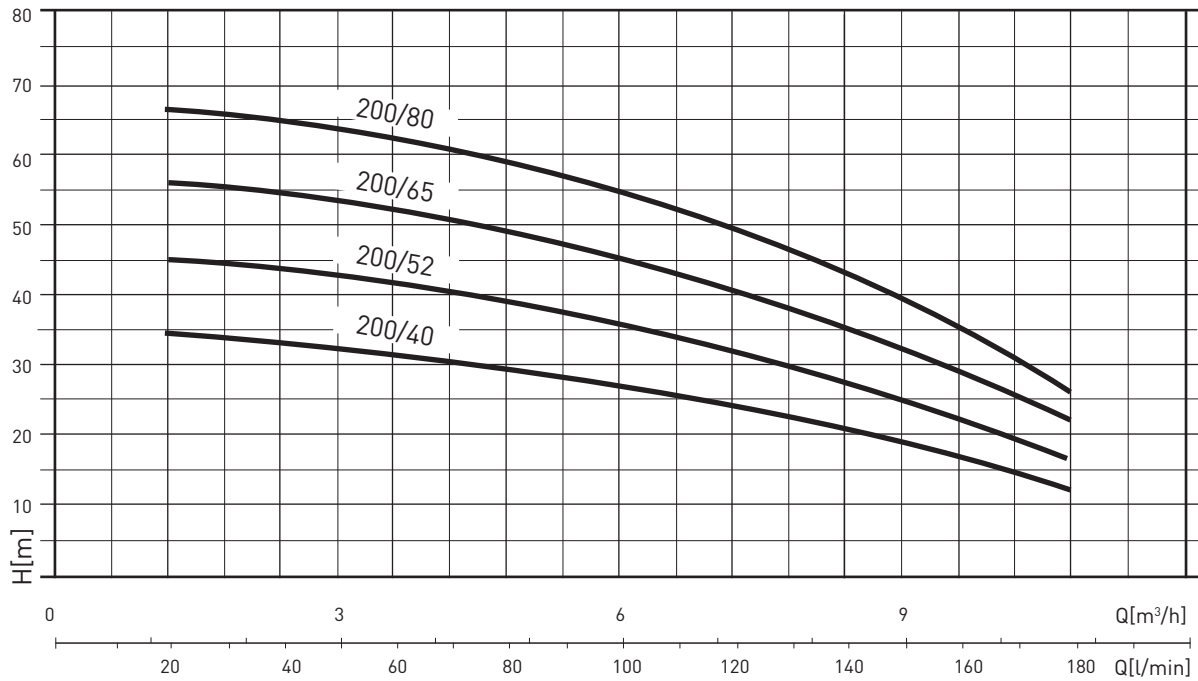

PERFORMANCE TABLE

MODEL	Motor output (P2)		Motor output (P1)		VOLT	In (A)	μF	Q	L/min m³/h	20	60	100	140	180
	HP	kW	HP	kW						1.2	3.6	6	8.4	10.8
MULTINOX-A 200/40 M MULTINOX-A 200/40 T	1.4	1	1.9 1.7	1.4 1.3	1 ~ 220 - 400 V 3 ~ 230 - 400 V	6.3 4-2.3	20	m.c.a. / m.w.c.	33.7	32.1	27.6	21.5	13.1	
MULTINOX-A 200/52 M MULTINOX-A 200/52 T	1.6	1.2	2.4 2.3	1.8 1.7	1 ~ 220 - 400 V 3 ~ 230 - 400 V	8.5 5.7-3.3	25		44.9	42.8	36.8	28.6	17.5	
MULTINOX-A 200/65 M MULTINOX-A 200/65 T	2	1.5	3 2.8	2.2 2.1	1 ~ 220 - 400 V 3 ~ 230 - 400 V	9.5 7.3-4.2	35		56.1	53.4	46	35.8	21.8	
MULTINOX-A 200/80 T	2.3	1.7	3.2	2.4	3 ~ 230 - 400 V	8.3-4.8			67.3	64.1	55.2	42.9	26.2	

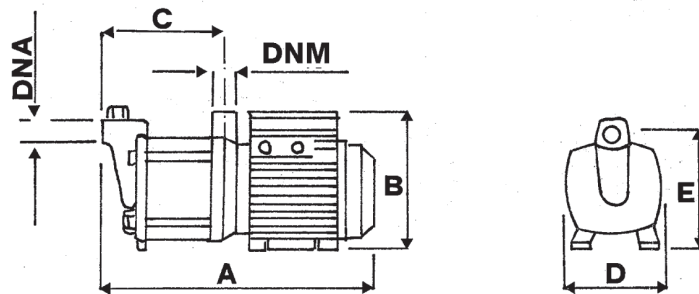

OVERALL DIMENSIONS AND WEIGHTS

MODEL	Dimensions (mm)							Weight (kg)
	A	B	C	D	E	DNA	DNM	
MULTINOX-A 200/40	441	200	188	155	170	1" 1/4	1" 1/4	19
MULTINOX-A 200/52	469	200	215	155	170	1" 1/4	1" 1/4	21
MULTINOX-A 200/65	497	200	243	155	170	1" 1/4	1" 1/4	23
MULTINOX-A 120/48	525	200	270	155	170	1" 1/4	1" 1/4	25