

JUNG PUMPEN WCFIX 260/260 A SEWAGE LIFTING STATION

APPLICATION

With the WCfix 260 and the WCfix 260 A it is possible to install an additional WC or an additional bathroom almost anywhere within the context of renovation or conversion works. When installed below the backup level, the device also provides anti-flooding protection.

The compact design of these pumping systems for restricted use allows the direct connection of a standing toilet with a minimum flush volume of 6 l.

The pumping is carried out particularly quietly by the flow-optimized open centrifugal impeller. Due to this design, regular cleaning is not necessary and servicing works are significantly reduced.

Due to the restricted use, the installation is only permitted if the number of users is small and an additional WC above the backup level is available to them. A washbasin, a shower and a bidet can also be connected in the same room. According to DIN EN 12050 part 3, further drainage facilities such as washing machines or bath-tubs may not be connected. We recommend the additional connection of a Hebefix sump. For entire apartments a compli pumping system should be used.

The WCfix 260 A is equipped with an integral alarm system for early acoustic fault signaling. It is also possible to pass on the fault signal to other places via a volt free contact fitted as standard.

The appliances are fully pre-assembled, ready for connection and operate fully automatically as soon as the flush is actuated. When installed in bath and shower rooms, the applicable electrical regulations must be observed.



WCfix 260

- Quiet
- Ready to connect
- Easy to maintain
- Protection against overflow
- Activated carbon filter
- Alarm system (WCfix 260 A)
- Vortex impeller

Max. horizontal length of pressure pipe
incl. 2 elbows and swing-type check valve 1 1/4"

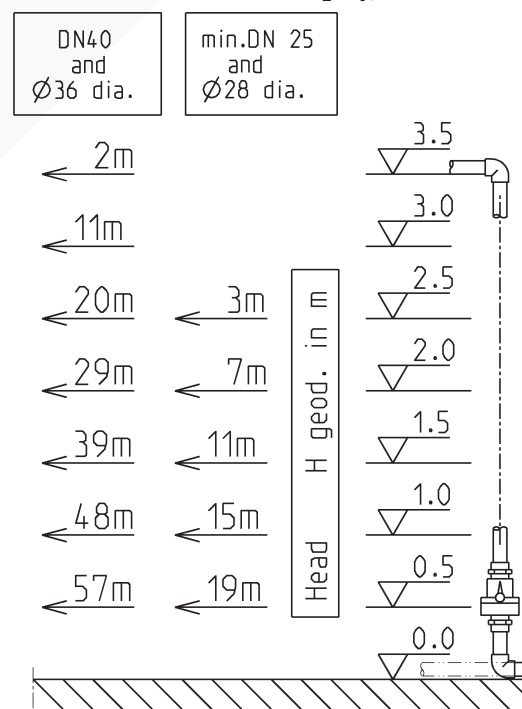

21552-04

JUNG PUMPEN WCFIX 260/260 A

SEWAGE LIFTING STATION

WCFIX 260

Type	Height x Width x Depth	Weight approx.	Code No.
WCfix 260	265 x 430 x 270 mm	6 kg	JP09268
WCfix 260 A	265 x 430 x 270 mm	6 kg	JP09269
Accessories: Stop valve 1¼"			JP44785

PERFORMANCE

Type	Delivery head H [m]	1	2	3	3,5	4
WCfix 260 / 260 A	Flow rate Q [l/min]	133	111	87	75	61

ELECTRICAL DATA

Type	Type of current	Voltage Volt	Motor rating kW		RPM min ⁻¹	Current Ampere	Cable quality	Cable length	Plug
			P ₁	P ₂					
WCfix 260/260 A	1-phase	1/N/PE~230	0.40	0.25	2610	1.75	H05VV-F-3G1.5	1.5 m	Safety-

Example of installation

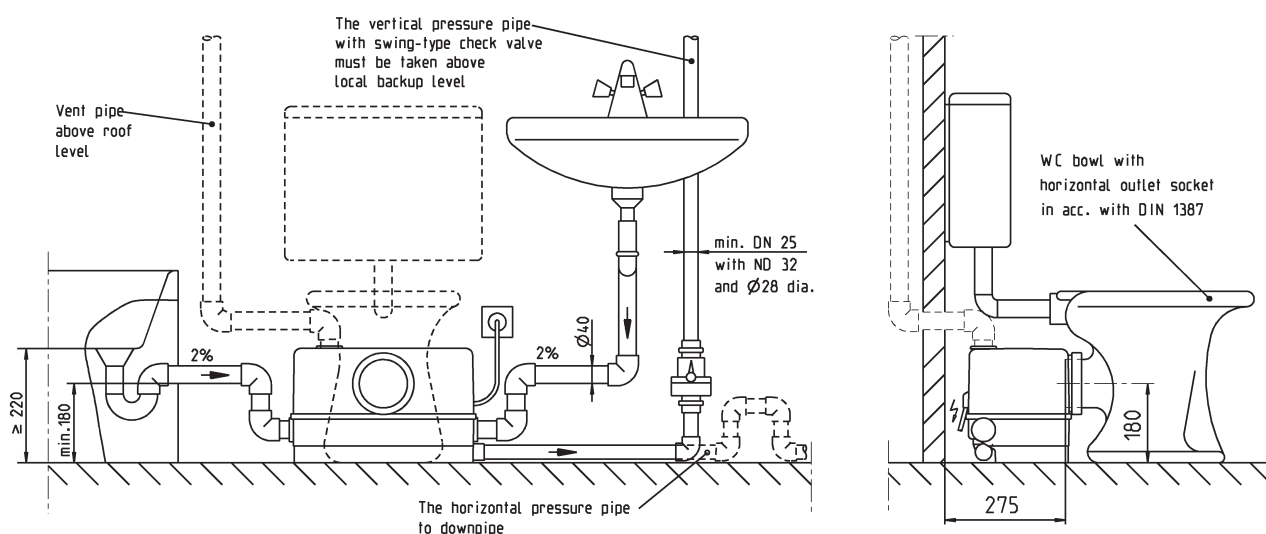

24953-03

JUNG PUMPEN WCFIX 260/260 A

SEWAGE LIFTING STATION

Installation instructions

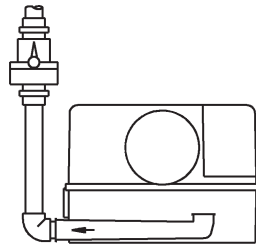
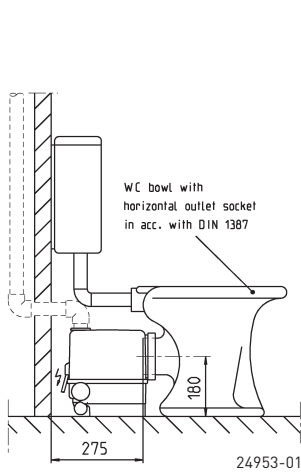

Pressure pipe vertical upwards. Fit with swing-type check valve and loop via the local backup level.

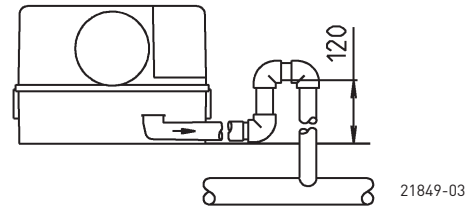

If the pressure pipe is installed entirely horizontally to the main pipe, a stagnation loop must be installed in the discharge line. If the pressure pipe is installed with the transition point of the pressure point situated below the installation of the system, the pressure pipe must be enlarged at its highest point by a pipe at least one ND larger. This prevents syphoning of the pressure pipe and vessel.

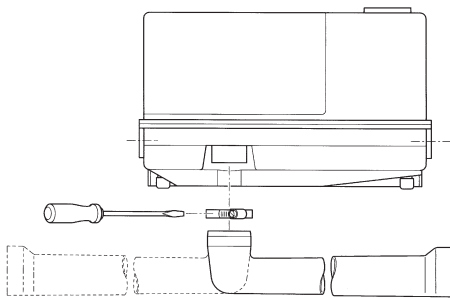

Stepped reducing elbow prepared for the connection of PVC-, PP- or PE-pressure outlet pipe with a rating of at least DN 25 with 32 ND and an ID of 28 mm or with a rating of DN 32 with 40 mm ND and an ID of 36 mm.

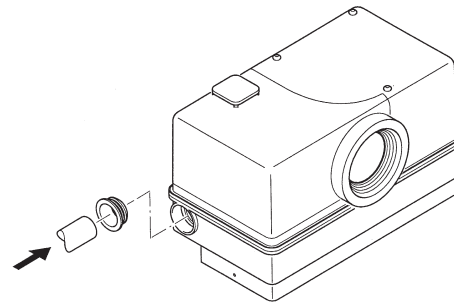

Connection of additional outlet points, e.g. wash basin, shower and bidet via drain pipes with size DN 40 with an ED of 40 mm.

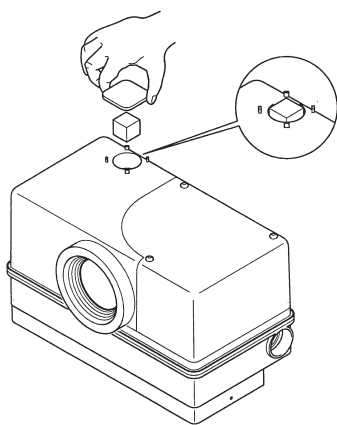

Fitting replacement of the activated carbon filter.

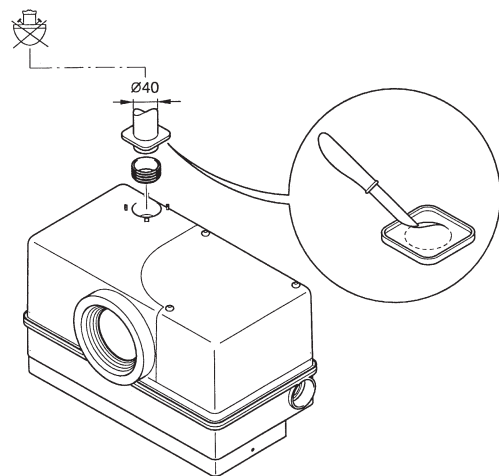

If odor is a problem there is a facility of connecting a vent pipe that leads above the roof level with size DN 40 with 40 mm ND and an ED of 40 mm.

Methods of installation others than those described could lead to malfunctions and invalidate the guarantee.

JUNG PUMPEN WCFIX 260/260 A

SEWAGE LIFTING STATION

TECHNICAL DATA

Construction

Splash-proof motor (protection category IP 24) in plastic housing on common shaft with impeller. Connection to toilet with rubber collar; flexible outlet hose bend for delivery connection (PVC-, PP- or PE) DN 25 with nominal diameter 32 or DN 32 with nominal diameter 40. Additional inlet (pipe diameter DN 40 with ND 40 and outer diameter of 40 mm).

Motor

Low-maintenance short-circuit rotor for intermittent service (3 min. operation, 7 min. interval) with operating capacitor and built-in thermal motor protection for overload release.

Control

Dynamic pressure level control, in case of WCfix 260 A with additional acoustic fault signal and potential-free contact for remote alarm indication. If additional facilities are connected, unit will automatically cope with increased input.

Materials

Motor housing and shaft made of stainless steel, tank, pump housing and impeller in synthetic material, plastic hose pipe.

Seal

Shaft sealed with rotary shaft seals and intermediate oil reservoir, safe to run dry.

Scope of supply

Device complies with DIN EN 12050, ready for connection with cable and plug, built-in vent valve, complete with inlet plug-in seal, discharge elbow, swing-type check valve 1¼", activated carbon filter, clips and fixing material.



Dimensions of WCfix 260/260 A (mm)

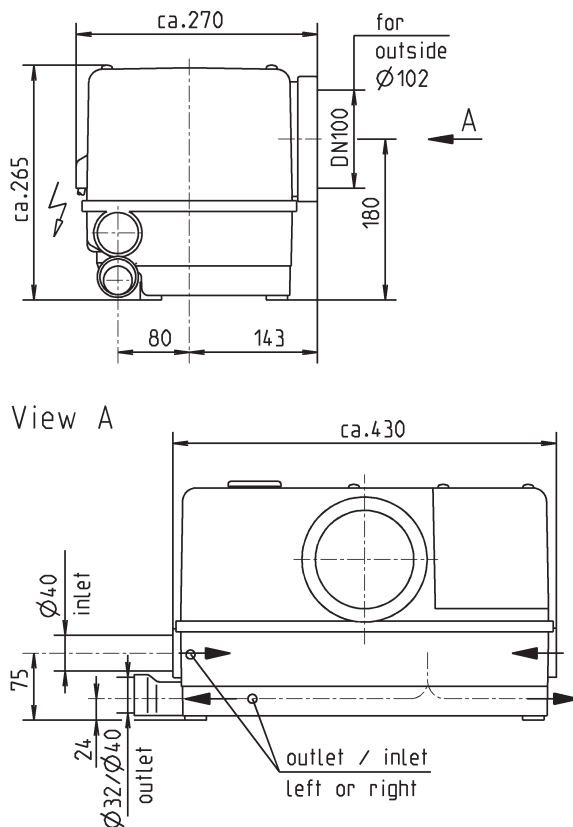

25274-01